

# **KeContact**

## **P40 / P40 Pro Charging Station Installation manual V 1.02**

**Translation of the original instructions**



Automation by innovation.

Document No.: 132016 | Version published: 09.2024  
Filename: KeContactP40\_ihen.pdf  
Pages: 98

© KEBA 2024

Specifications are subject to change due to further technical developments. Details presented may be subject to correction.

All rights reserved.

**KEBA Energy Automation GmbH**

Reindlstraße 51, 4040 Linz, Austria, [www.keba.com/emobility](http://www.keba.com/emobility)  
☎ +43 732 7090-0, 🏠 +43 732 7309-10, ✉ [kecontact@keba.com](mailto:kecontact@keba.com)

For information about KEBA and our subsidiaries please look at [www.keba.com](http://www.keba.com).

## Table of contents

<b>1</b>	<b>Introduction.....</b>	<b>6</b>
1.1	Representation of safety instructions.....	6
1.2	Purpose of the document.....	7
1.3	Requirements.....	7
1.4	Intended use .....	7
1.5	Warranty .....	8
1.6	Notes on this document .....	8
<b>2</b>	<b>Safety notes .....</b>	<b>9</b>
<b>3</b>	<b>Scope of delivery .....</b>	<b>11</b>
<b>4</b>	<b>Description of the charging station .....</b>	<b>12</b>
4.1	Front view .....	12
4.2	Rear view .....	14
4.3	View from below.....	14
4.4	Type plates .....	15
4.5	Product key (variants of the charging station).....	16
<b>5</b>	<b>Status displays .....</b>	<b>18</b>
5.1	LED bar (status display).....	18
5.2	Displays in event of error .....	20
5.3	Displays during configuration.....	20
<b>6</b>	<b>Optional operating elements .....</b>	<b>21</b>
6.1	RFID reader .....	21
6.2	Touch button .....	21
6.3	Smart charging symbol .....	22
<b>7</b>	<b>Power supply and line dimensioning .....</b>	<b>23</b>
<b>8</b>	<b>Mounting and installation instructions .....</b>	<b>25</b>
8.1	General criteria for the site selection .....	26
8.2	Required tools.....	27
8.3	Installation specifications and space requirement .....	27
8.4	Preparing the charging station for installation.....	29
8.5	Mounting the charging station.....	31
8.6	Notes on cable routing .....	33
<b>9</b>	<b>Electrical connections and wiring .....</b>	<b>35</b>
9.1	Required tools.....	35

9.2	Voltage zones .....	35
9.3	Connecting the voltage supply .....	36
9.4	Electrical connection to special systems of AC power supply .....	38
9.5	Connection overview of the application module.....	39
9.6	Switch contact inputs [X1a] / [X1b] .....	40
9.7	Switch contact output [X2] .....	42
9.8	Network connection (LAN) [X3].....	45
9.9	RS485 interface* [X4] (for external energy meter).....	47
9.10	Switching on the power supply .....	49
<b>10</b>	<b>Wireless connections.....</b>	<b>50</b>
10.1	WLAN connection .....	50
10.2	Mobile network communication (LTE option).....	50
<b>11</b>	<b>Configuration .....</b>	<b>52</b>
11.1	Activating/deactivating installation mode .....	53
11.2	Basic electrical configuration directly at the device.....	54
11.3	Establishing an app connection via Bluetooth®.....	55
11.4	Basic electrical configuration and parameterization using the app.....	55
11.5	Operation and extended configuration using the app .....	57
11.6	Activating/deactivating Bluetooth® .....	58
11.7	Displays during configuration.....	59
<b>12</b>	<b>Commissioning.....</b>	<b>60</b>
12.1	Perform safety checks .....	60
12.2	Mounting covers / Sealing.....	61
12.3	Mounting the plug holder .....	63
<b>13</b>	<b>RFID authorization.....</b>	<b>64</b>
13.1	Authorization modes .....	64
<b>14</b>	<b>Special functions.....</b>	<b>66</b>
14.1	Integration of an external energy meter.....	66
14.2	Connection of an external energy meter (Modbus TCP) .....	67
14.3	Connection of an external energy meter (RTU)*.....	67
14.4	Supported external energy meters.....	68
14.5	Dynamic domestic connection monitoring .....	69
14.6	PV-optimized charging.....	70
14.7	Remote control by the power grid operator.....	72
14.8	Smart Home Interface.....	72
14.9	Charging profiles.....	73
14.10	Tamper detection.....	73

<b>15</b>	<b>OCPP backend</b> .....	<b>74</b>
<b>16</b>	<b>Short description of the eMobility App</b> .....	<b>76</b>
16.1	Establishing an app connection via Bluetooth®.....	78
16.2	Establishing an app connection via LAN/WLAN .....	78
<b>17</b>	<b>Short description of the eMobility portal</b> .....	<b>79</b>
<b>18</b>	<b>Maintenance</b> .....	<b>81</b>
18.1	Software update.....	81
18.2	Troubleshooting .....	82
<b>19</b>	<b>Accessories</b> .....	<b>83</b>
19.1	Floor-mounted columns .....	83
<b>20</b>	<b>Disposal</b> .....	<b>84</b>
<b>21</b>	<b>Technical data</b> .....	<b>85</b>
21.1	General .....	85
21.2	Power supply .....	85
21.3	Charging cable.....	86
21.4	Ambient conditions.....	86
21.5	Interfaces .....	86
21.6	Equipment depends on version .....	88
21.7	Internal protective functions .....	88
21.8	Dimensions and weight.....	90
<b>22</b>	<b>EU Directives and Standards</b> .....	<b>91</b>
<b>23</b>	<b>Country-specific characteristics</b> .....	<b>92</b>
23.1	Country-specific settings for Great Britain / United Kingdom.....	92
23.2	Country-specific characteristics for Germany .....	92
	<b>Index</b> .....	<b>93</b>

# 1 Introduction

This manual is valid for the KeContact P40.

The pictured devices used in this manual are visual examples. The figures and explanations contained in this manual refer to a typical device design. The devices used by you may differ in their appearance.

We recommend always keeping the charging station updated to the most recent software version, as this contains functional enhancements and product improvements.

## 1.1 Representation of safety instructions

At various points in this manual, you will see notes and precautionary warnings regarding possible hazards. The symbols used have the following meaning:



---

### **DANGER!**

Indicates an imminently hazardous situation, which will result in death or serious bodily injury if the corresponding precautions are not taken.

---



---

### **WARNING!**

Indicates a potentially hazardous situation, which can result in death or serious bodily injury if the corresponding precautions are not taken.

---



---

### **CAUTION!**

Means that if the corresponding safety measures are not taken, a potentially hazardous situation can occur that may result in slight bodily injury.

---

---

### **Caution**

Means that damage to property can occur if the corresponding safety measures are not taken.

---



---

### **ESD**

This symbol reminds you of the possible consequences of touching electrostatically sensitive components.

---

---

### **Information**

*Identifies practical tips and useful information. No information that warns about potentially dangerous or harmful functions is contained.*

---

## 1.2 Purpose of the document

This document describes the installation and configuration of KeContact P40.

This document is an extension of the supplied manuals for the KeContact P40.

**You must comply with all instructions and safety notes in the supplied manuals!**

## 1.3 Requirements

This document contains information for persons who meet the following requirements:

Target group	Required knowledge and abilities
Electrician	<p>Person who, due to their special training, expertise and experience as well as knowledge of current standards, is able to assess the work performed and the possible hazards.</p> <p>Knowledge about:</p> <ul style="list-style-type: none"> <li>• Currently valid safety regulations</li> <li>• Basics of network technology</li> <li>• Systematic fault analysis and troubleshooting</li> </ul>

## 1.4 Intended use

The charging station is intended for charging electrically powered vehicles (e.g. e-cars). The connection of other devices (such as power tools) is not allowed.

Vehicle charging which requires ventilation is not supported.

The charging station is suitable for indoor and outdoor use. The charging station must be installed vertically on a wall or floor-mounted column. The subsurface for installation must be flat and have the corresponding carrying capacity (e.g. brick wall, concrete wall). The respective national regulations must be observed with regard to the installation and connection of the charging station.

The intended use of the device always includes the compliance with the environmental conditions for which this device was developed.

KeContact P40 has been developed, manufactured, tested and documented in accordance with the appropriate safety standards. Therefore, provided that the instructions and safety precautions relating to the intended use are observed, the products do not pose any danger to the health of personnel or a risk of damage to other property or equipment under normal circumstances.

## 1.5 Warranty

Only general maintenance work that is expressly permitted by KEBA may be performed. Any other tampering to the device will result in a loss of the warranty claim.

Only those covers that are described in the procedure instructions are allowed to be opened. If one of the covers is sealed by a lead seal, it is not permitted to be opened by unauthorized persons. If the lead seal is broken, the device loses its specific suitability for use and may no longer be put into operation due to the resulting incorrect identifier.

No activities that cause the manufacturer's seal to be broken may be carried out. A broken manufacturer's seal voids any warranty claims. For a warranty claim, there is a duty of proof of the customer that the defect – which led to the defect of the device – already existed at the time of delivery. If the manufacturer's seal is broken, this proof can no longer be provided, resulting in expiration of the warranty claim.

A device with a broken manufacturer's seal or removed lead seal may no longer be put into operation. The necessary steps must be taken for having the charging station replaced or repaired by a specialist dealer or service partner.

## 1.6 Notes on this document

The manuals are part of the product and must be read and understood before installation and initial use.

The current manuals can be downloaded directly from our homepage:  
[www.keba.com/emobility-downloads](http://www.keba.com/emobility-downloads)

The downloaded manuals must be kept for the entire life of the product. If you require the information in another language, please contact your customer advisor.

In addition to the safety notes in this manual, the applicable safety and accident prevention regulations for the application must be observed.

### Contents of the document

- Description of the charging station
- Assembly of the charging station
- Electrical installation of the charging station
- Commissioning of the charging station
- Configuration of the charging station
- Maintenance of the charging station

### Mention of names

The Bluetooth® word mark and logos are registered trademarks owned by Bluetooth SIG, Inc. and any use of such marks by KEBA is under license. Other trademarks and trade names are those of their respective owners.

## 2 Safety notes



---

### WARNING!

#### Risk of electric shock and fire hazard!

- All work on the charging station that requires opening the protective cover must be performed by correctly trained, qualified and authorized electricians<sup>1)</sup> who are fully responsible for compliance with existing standards, tests and installation regulations.
- An upstream main switch must be used to interrupt the power supply.
- The charging station may only be installed and operated in a perfect condition. A damaged charging station must be promptly taken out of service and repaired or replaced by a qualified and authorized electrician<sup>1)</sup>.
- Repairs may only be made to the charging station by trained electricians<sup>1)</sup> with replacement parts approved by the manufacturer and checked before installation.
- No unauthorized conversion work or modifications may be made to the charging station.
- The charging station may only be stored and transported with the protective cover closed and in the original packaging.
- Markings must not be removed from the charging station or made illegible.
- The charging station and charging cable must be checked regularly to ensure that they are in proper condition. Never use faulty, worn-out or dirty charging plugs or charging cables.
- Using cable extension sets or adapters of any kind is prohibited.

---

<sup>1)</sup> Persons who, due to their special training, expertise and experience as well as knowledge of current standards, are able to assess the work performed and the possible hazards.



---

**WARNING!****Risk of electric shock and fire hazard!**

- Please observe that an additional overvoltage protection can be required by vehicles or national regulations.
  - Also note that some countries or vehicle manufacturers may require the residual current circuit breaker to have a different tripping characteristic (Type B).
  - The supply line must be permanently routed with regard to the selected installation type (especially in case of supply from below without a PG screw connection).
  - Every charging station of type P40-...-XXXXDXXX-...-... must be connected using a separate residual current device. A Type A residual current circuit breaker can be used instead of a Type B, since all variants have internal DC residual current monitoring  $\geq 6$  mA.
  - During installation, be sure to select a suitable circuit breaker; see the dimensioning instructions in the "Installation manual".
  - Only open housing parts that are intended to be opened according to the manual.
  - Before working on the charging station, it must be ensured that the charging station is in a de-energized state.
  - Do not use any components of the charging station as standalone equipment.
- 

**Caution****Possible damage to property!**

- When connecting and wiring the charging station, ensure that the connection area is clean so that no foreign objects (pieces of wire, etc.) get inside the charging station.
  - When the charging cable is not in use, always plug it into the plug holder or use a suitable plug protective cover.
  - Pull the charging cable out of the plug holder only by the plug and not by the cable.
  - To clean the charging station, use only solvent-free cleaning agents without anionic surfactants.
- 

**Not observing the safety notes can result in risk of death, injuries and damage to the device!**

The device manufacturer does not accept any liability for claims that result from non-compliance with the safety notes!

### 3 Scope of delivery

The following parts are included in the scope of delivery:

#### Basic elements

Description	KeContact P40	KeContact P40 Pro
Charging station with charging cable	1x	1x
Plug holder	1x	1x
Drilling template	1x	1x
Safety notes and short manual	1x	1x
RFID card	1x (option)	1x

#### Mounting set for wall installation

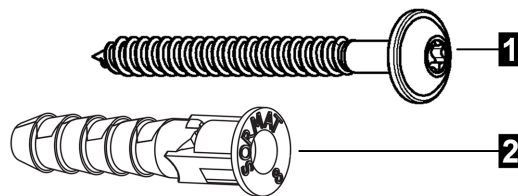

No.	Mounting material - Charging station	Number
<b>1</b>	Wafer-head screws ST 5.5 x 53 mm	3
<b>2</b>	Dowel Ø8 mm	3

No.	Mounting material - Plug holder	Number
<b>1</b>	Wafer-head screws ST 5.5 x 53 mm	2
<b>2</b>	Dowel Ø8 mm	2

	Installation material - Covers	Number
	Screw covering caps (for the plug holder)	2
	Terminal cover	1

If the included mounting material is not used, for safety reasons, equivalent mounting must be used which can bear a weight of 90 kg (30 kg per mounting point).

## 4 Description of the charging station

### 4.1 Front view

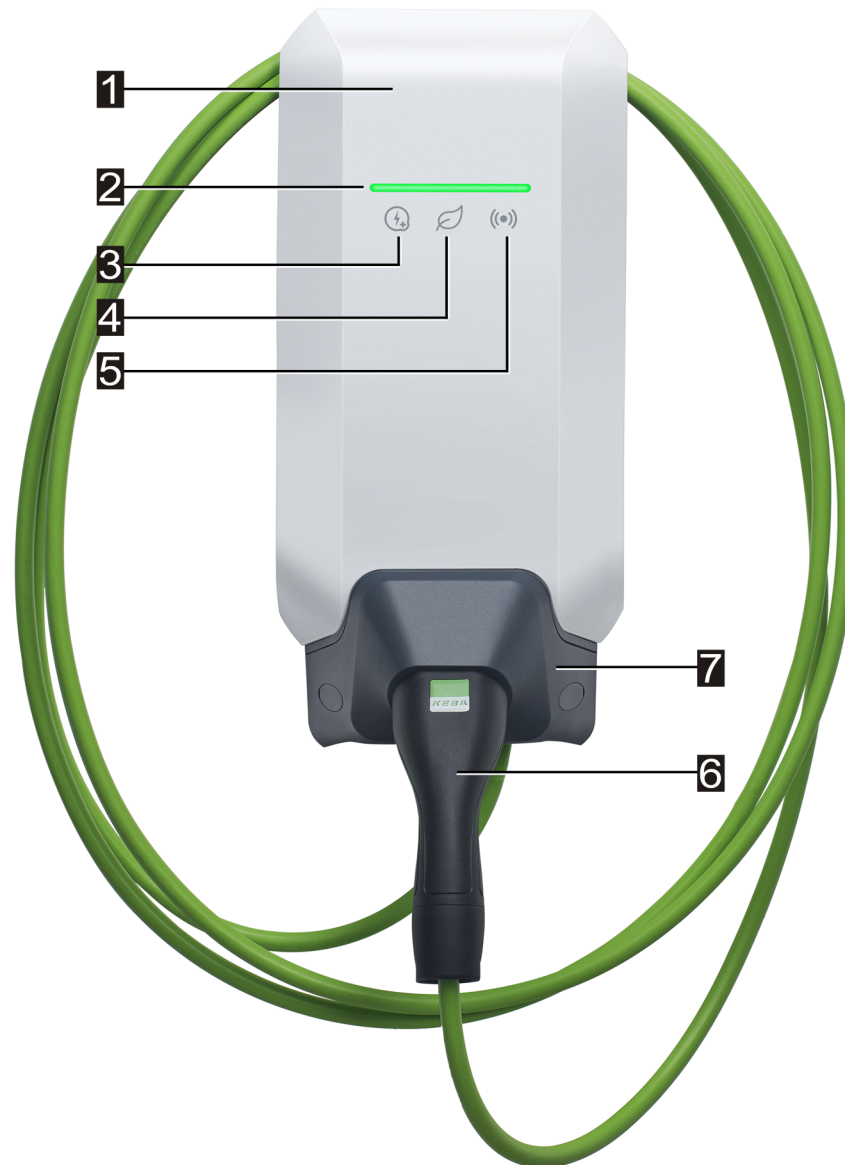

<b>1</b> ... Housing cover	<b>2</b> ... LED bar (status display)
<b>3</b> ... Touch button	<b>4</b> ... Smart charging symbol
<b>5</b> ... RFID reader	<b>6</b> ... Charging plug with charging cable
<b>7</b> ... Plug holder	

Depending on the design of the charging station, the colors or functions may differ from the illustration.

### Plug holder



The plug holder for the charging cable can be installed directly beneath or separately from the charging station.

#### **Information**

*If the plug holder for the charging cable is installed directly beneath the charging station, it can be used to secure the housing cover.*

## 4.2 Rear view

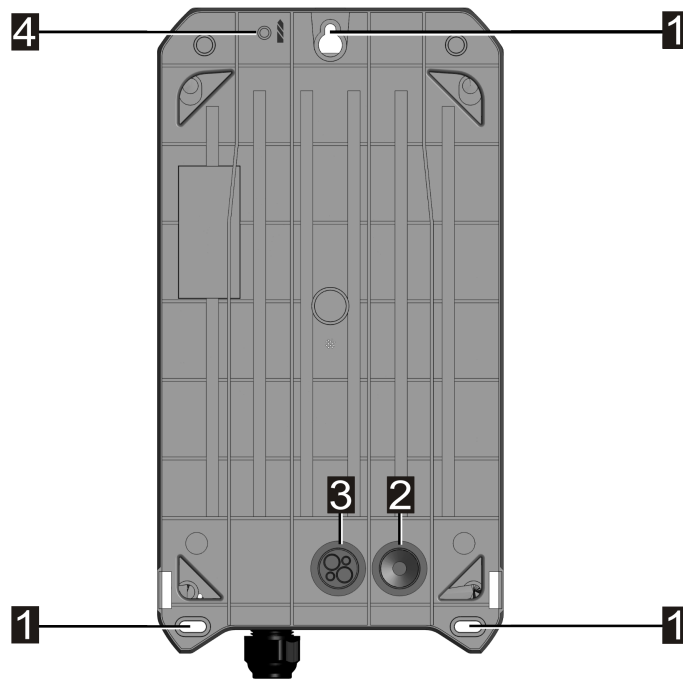

<b>1</b> ... Mounting holes	<b>2</b> ... Flush-mounted cable opening (for supply line)
<b>3</b> ... Flush-mounted cable opening (for control lines)	<b>4</b> ... Off-center substitute hole position

## 4.3 View from below

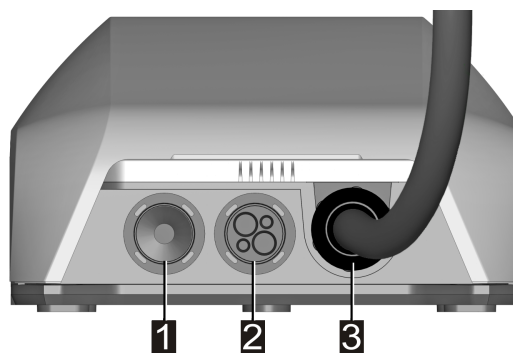

<b>1</b> ... Surface-mounted cable opening (for supply line)	<b>2</b> ... Surface-mounted cable opening (for control lines)
<b>3</b> ... Fixed-mounted charging cable	

### 4.4 Type plates

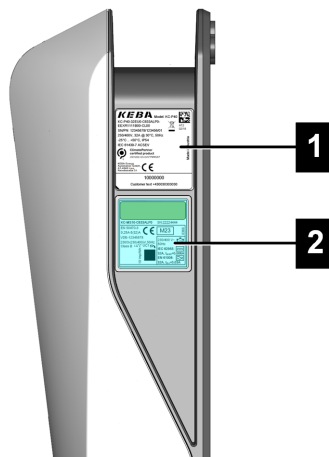

<b>1</b> ... Type plate of the charging station	<b>2</b> ... Type plate of the installed KC-MS10 module
---	---

The two type plates are located on the right side of the charging station.

#### Information

*The type plates shown below represent the maximum characteristics. Type plates may contain less data depending on the device variant.*

#### Type plate of the charging station

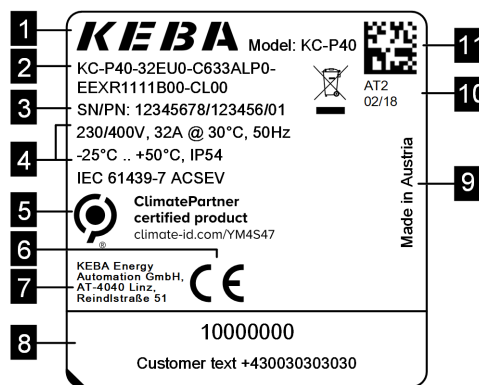

<b>1</b> ... Manufacturer	<b>2</b> ... Product key
<b>3</b> ... Serial number / Material number	<b>4</b> ... Electrical data
<b>5</b> ... ClimatePartner certification	<b>6</b> ... CE marking
<b>7</b> ... Manufacturer address	<b>8</b> ... Operator information
<b>9</b> ... Country of manufacture	<b>10</b> ... Production location and date
<b>11</b> ... Serial number as a QR code	

**Type plate of the KC-MS10**

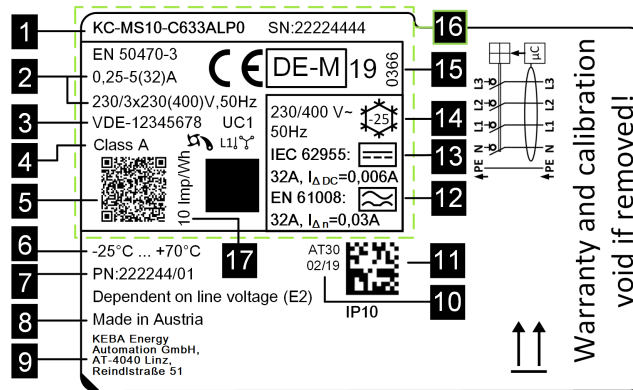

<b>1</b> ... Product key / Serial number	<b>2</b> ... Electrical data
<b>3</b> ... Type examination number	<b>4</b> ... Accuracy class
<b>5</b> ... Public key information	<b>6</b> ... Operating temperature range
<b>7</b> ... Material number	<b>8</b> ... Country of manufacture
<b>9</b> ... Manufacturer address	<b>10</b> ... Production location and date
<b>11</b> ... Serial number as a QR code	<b>12</b> ... Electrical data RCD
<b>13</b> ... Electrical data RDC	<b>14</b> ... Electrical data RCD+RDC
<b>15</b> ... Marking of the approval	<b>16</b> ... Visible part of the type plate
<b>17</b> ... Meter constant	<b>CE</b> ... CE marking

**4.5 Product key (variants of the charging station)**

KC-P40- 32 EU 0 - C 6 S 3 A L P 0 - L S 1 R 1 1 1 B L 0 - xxxx  
 I II III IV V VI VII VIII IX X XI XII XIII XIV XV XVI XVII XVIII XIX XX XXI XXII XXIII XXIV

Form designation system (example)			
I	Device series	<b>KC-P40</b>	...Device generation
II	Nominal current	<b>16</b> <b>32</b>	...16 A ...32 A
III	Region	<b>EU</b> <b>GB</b>	...Europe ...Great Britain
IV	Future options	<b>0</b>	...none
V	Connector	<b>C</b> <b>P</b> <b>T</b> <b>N</b>	...type 2 cable ...type 2 cable with protective cap ...type 2 cable with shutter ...cable variant, no cable attached
VI	Cable	<b>0</b> <b>4</b> <b>6</b>	...no cable ...cable 4m ...cable 6m
VII	Phases	<b>1</b> <b>3</b> <b>S</b>	...1 phase ...3 phases ...3 phases→1 phase (phase switching)

VIII	Maximum Charging Current	1 ...16 A 3 ...32 A
IX	RCD functionality	A ...RCCB Type A + RDC-DD D ...RDC-DD
X	Metering	0 ...not equipped E ...functional, not calibrated M ...MID (Measuring Instruments Directive) certified L ...MessEV (Mess- und Eichverordnung) certified
XI	PLC	0 ...not equipped P ...PLC communication
XII	Future options	0 ...none
XIII	LAN	0 ...not equipped L ...LAN interface
XIV	Serial meter interface	0 ...not equipped S ...Serial meter interface (RS485)
XV	I/O interface	0 ...not equipped 1 ...Switch contact inputs and output
XVI	RFID	0 ...not equipped R ...RFID functionality
XVII	SRWC	0 ...not equipped 1 ...Short range wireless communication (Bluetooth®)
XVIII	WLAN	0 ...not equipped 1 ...WLAN module
XIX	Mobile communication	0 ...not equipped 1 ...LTE module (4G)
XX	Processing unit	0 ...Variant 0 1 ...Variant 1
XXI	Touch button	0 ...not equipped B ...Touch button
XXII	User interface	L ...LED
XXIII	Future options	0 ...None
XXIV	Customer options	xxxx Options for individual customer versions, not relevant for EU declaration of conformity

## 5 Status displays

The charging station has an LED bar for the display of the operating states and a smart charging symbol (optional) for the display of an intelligent charging current specification.

### Audio signals

The installed buzzer uses various audio signals to aid in operation based on the operating state.

### 5.1 LED bar (status display)



The LED bar (1) provides visual information about the current operating state of the charging station and can light up, flash or pulse in different colors.

The LED bar is only visible with activated power supply.

### Information on the display of status displays



	Indicates that the LED bar lights up continuously.
	Indicates that the LED bar flashes in different manners or speeds.
	Indicates that the LED bar pulses at a consistent speed.

### Example

The diagram shows a horizontal timeline from 0s to 5s. A green bar is shown from 0s to 0.5s, then a gap from 0.5s to 1s, then another green bar from 1s to 1.5s, and so on, repeating every 1 second. An arrow points from the 5s mark to a square wave icon with green bars, representing the flashing pattern.

The light pattern explanations are shown in a short time sequence for a duration of 5 seconds. The example shows that the entire LED bar flashes green for 0.5 seconds every 5 seconds.

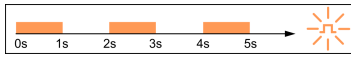
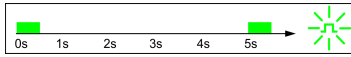
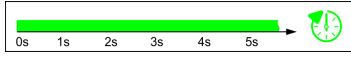
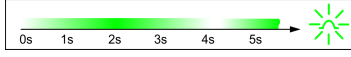

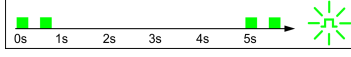
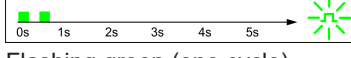
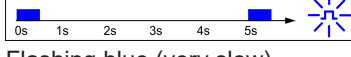
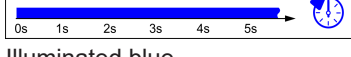
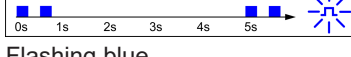
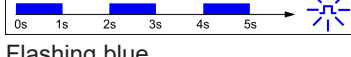
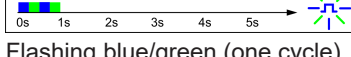
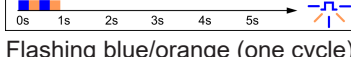
**Common operating states**

LED bar	Description
 <p>Flashing orange</p>	<ul style="list-style-type: none"> <li>The charging station is being started.</li> <li>The charging station is performing a self-test upon start-up (with audio signal).</li> <li>Software update of parts of the charging station related to safety technology or measuring technology.</li> </ul>
 <p>Flashing green (very slow)</p>	<p>Charging station is ready and no vehicle is connected. No authorization is required.</p>
 <p>Illuminated green</p>	<p>Charging station is ready, a vehicle is connected but has not yet requested charging. No authorization is required.</p>
 <p>Pulsing green</p>	<p>The vehicle is charged.</p>
<p>Optional</p> 	<p>If the smart charging symbol is also flashing, smart charging current control is also active and limits the possible charging current.</p>
 <p>Flashing green</p>	<ul style="list-style-type: none"> <li>Charging station is ready, a vehicle is connected but has not requested charging in the last 5 minutes.</li> <li>The charging process request was ended by the vehicle.</li> <li>The charging process is blocked by the charging station (e.g. vehicle not ready, switch contact input or load management specification).</li> </ul>
 <p>Flashing green (one cycle)</p>	<p>KEBA eMobility App can be used to start identification of the charging station. The charging station emits a short flashing signal and audio signal in order to be identified.</p>
 <p>Flashing blue (very slow)</p>	<p>The charging station is ready but no vehicle is connected. Authorization is required.</p>
 <p>Illuminated blue</p>	<p>Charging station is ready, vehicle is connected but authorization has not yet been performed via RFID card or switch contact input.</p>
 <p>Flashing blue</p>	<p>Charging station is ready but authorization was not performed within 5 minutes.</p>
 <p>Flashing blue</p>	<p>The RFID card has been read and is being checked for validity (with audio signal).</p>
 <p>Flashing blue/green (one cycle)</p>	<p>The RFID card has been accepted and the charging process can start (with audio signal).</p>
 <p>Flashing blue/orange (one cycle)</p>	<p>The RFID card has been rejected (with audio signal).</p>

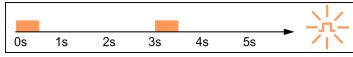
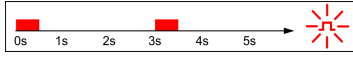
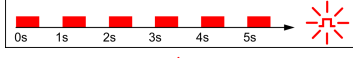
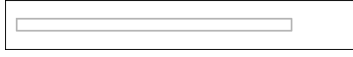
## 5.2 Displays in event of error

LED bar	Description
 <p>Flashing orange</p>	<p>The charging station has detected an error (e.g. temperature too high) and attempts to remedy it. The status flashes until the error has been remedied. No activity by the operator required.</p>
 <p>Flashing red</p>	<p>Error that requires an action (with one-time audio signal after occurrence of the error).</p> <p>Possible actions by the operator:</p> <ul style="list-style-type: none"> <li>• Unplug the charging plug and plug it back in.</li> <li>• Restart the charging station by switching the upstream disconnection device (e.g. circuit breaker) of the supply line off and on again.</li> <li>• Residual current device (RCD) has tripped. Check the plug and cable for damage and repeat the charging process. If the error occurs more frequently, have the vehicle checked.</li> </ul>
 <p>Flashing red</p>	<p>Serious error (with one-time audio signal after occurrence of the error).</p> <ol style="list-style-type: none"> <li>1) Switch off the power supply to the charging station by switching off the upstream disconnection device (e.g. circuit breaker) on the supply line.</li> <li>2) Have the charging station checked by an electrician.</li> </ol>
 <p>No display</p>	<p>No power supply or defect.</p>

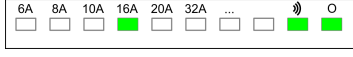
## 5.3 Displays during configuration

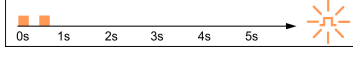
LED bar	Description
 <p>Parameter illuminated green / Smart charging symbol illuminated green</p>	<p>If the Service key is pressed once briefly, the current configuration is shown on the LED bar for 5 seconds (see <a href="#">"11.2 Basic electrical configuration directly at the device"</a>).</p>
 <p>Parameter flashing orange / Smart charging symbol illuminated orange</p>	<p>Installation mode was activated. The charging current limit can be set on the device or with the app (see <a href="#">"11.1 Activating/deactivating installation mode"</a>).</p>
 <p>Flashing orange (2x short)</p>	<p>Installation mode was ended using the Service key and settings have been saved.</p>

The ampere values shown in the illustrations are printed on the housing of the charging station.

## 6 Optional operating elements

The pictured devices used in this manual are visual examples. The figures and explanations contained in this manual refer to a typical device design. The devices used by you may differ in their appearance.

### 6.1 RFID reader

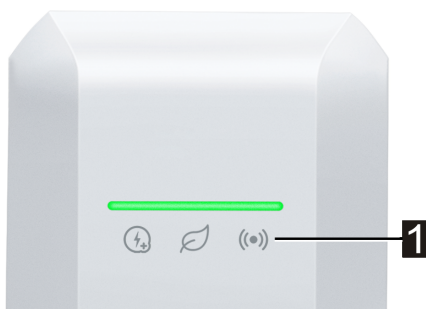

The RFID reader **1** is used for non-contact authorization of a charging process using cards, tags or a smartphone in accordance with ISO 14443 and ISO 15693.

### 6.2 Touch button





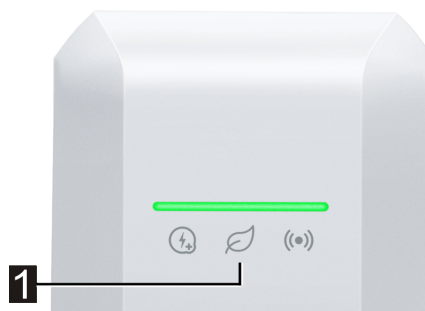

If the charging current is limited by a smart charging current specification, the smart charging symbol lights up. In this case, the charging current limit can be waived once for the current charging session using the touch button **1** (contact surface), if this is permitted by the grid operator. This charges the vehicle faster, if needed.

### 6.3 Smart charging symbol



The smart charging symbol (1) indicates whether smart charging current specifications are currently reducing the maximum charging power. This can cause the charging process to take longer.

Display	Description
 No display	The charging station operates with the full, pre-configured power.
  Green / blue	Smart charging current control is active and limits the possible charging current (PV-optimized charging, switch contact input, OCPP charging profile, etc.). This makes the charging process take longer. Color and animation follow the display on the light bar.
 Orange	The charging current is currently limited because there is no connection to the higher-level control system (e.g. due to a network problem). The animation follows the display on the light bar.
 Red	The charging station is in a critical error state. The animation follows the display on the light bar.

## 7 Power supply and line dimensioning

### Power supply line

The supply line (power supply) must be **permanently routed** into the existing domestic installation and must correspond to the applicable national legal regulations. The supply line must not be a freely movable line.

When dimensioning the power supply line also observe the possible reduction factors and the increased environmental temperatures inside the connection area of the charging station (see temperature rating of the supply terminals)! Under certain circumstances, this can lead to an increase of the cable cross-section and to needing extended temperature resistance for the supply line.

### Power supply disconnection device

The device has a disconnection device. However, this is not used to disconnect the device from voltage, but only serves as additional protection (no load disconnecter). Therefore, a suitable isolation device for disconnecting the voltage (e.g. circuit breaker, isolator switch or equivalent means of isolation) must be provided as part of the building's electrical system. The intended disconnection device must always be used to interrupt the supply voltage.

### RCD (residual current device)

All variants of the charging station have integrated DC residual current monitoring  $\geq 6$  mA (RDC-DD).

All charging stations of type "P40-...-xxxx**A**xxx-..." have an integrated type A RCD (residual current device).

All charging stations of type "P40-...-xxxx**D**xxx-...-..." must be connected using a separate residual current device. A Type A residual current circuit breaker can be used instead of a Type B.

### Overcurrent protection for residual current devices

During installation, the use of an appropriate upstream overcurrent protection device  $\leq 35$  A gG (gL) must be ensured for the integrated residual current device.

When dimensioning, increased ambient temperatures in the control cabinet must also be taken into account! Under certain circumstances, this can make a reduction of the charging current specification necessary in order to increase the system availability.

For the device variants of the "Early Access Edition" (KC-P40-16EUS-C6S1AEP0-LS1R1111BL0-WH00 and KC-P40-16EUS-C6S1AEP0-LS1R1111BL0-BK00), the use of a suitable upstream overcurrent protection device  $\leq 25$  A gG (gL) must be observed.

### Line circuit breaker

When dimensioning the circuit breaker, the increased ambient temperatures in the control cabinet must also be taken into account! Under certain circumstances, this can make a reduction of the charging current specification necessary in order to increase the system availability.

The rated current must be determined in accordance with the type plate data in coordination with the desired charging power and the supply line.

### Charging current specification

The charging station is set to 16 A in the delivery state. To adjust the maximum current to the installed circuit breaker, the charging current must be configured using the Service key or using KEBA eMobility App.

## 8 Mounting and installation instructions

Depending on the scope of delivery, a mounting set for wall mounting is available. The mounting set is suitable for cement, brick and wood (without anchors). For other surfaces, a suitable method of installation must be selected.

In special installation situations, the mounting materials must be provided by the customer. Proper installation is absolutely necessary and lies outside of the scope of responsibility of the manufacturer.

The plug holder must be permanently installed in an appropriate manner for the subsurface.



### **WARNING!**

#### **Risk of electric shock and fire hazard!**

- Take care to ensure that the installation substructure has sufficient load-bearing capacity; choose means of assembly accordingly. For installation on hollow walls, at least one mounting screw of the charging station and one of the plug holder must be secured to a support element of the wall.
- The process of drilling the mounting holes must not damage the installation lines. If necessary, use the alternative, off-center drill hole.
- If the chosen type of installation requires strain relief, attach a cable gland.
- The connector panel is never permitted to be left open unattended. Before the charging station is left, the protective cover must be mounted.

---

### **Caution**

#### **Risk of breaking the plastic housing!**

- The mounting surface must be level and completely cover the back side of the charging station.
  - Choose a suitable tightening torque for the mounting screws that is appropriate for the subsurface; however, the tightening torque must not exceed 7 Nm.
-

---

## Caution

### Property damage due to dampness and moisture!

- If a cold charging station is brought into a significantly warmer environment (e.g. after transport in a cold environment), condensation may form in the device. Before connecting the charging station to the power supply, you must wait until the temperature of the charging station is the same as the ambient temperature and the moisture has evaporated again.
  - During outdoor installation, the protective cover must not be opened in unsuitable weather (rain, wind, snow, etc.) unless suitable weather protection is used.
  - When installing the charging station, make sure that no pools of water can form during operation.
  - The charging station must always be fully and properly equipped with seals for the cable openings. If seals of unused cable openings are cut open, they must be screwed shut with dummy plugs to ensure leaktightness.
- 

## 8.1 General criteria for the site selection

The charging station was constructed for the indoor and outdoor area. The following criteria must be taken into account when selecting a location:

- Take into account the local electrical installation regulations, fire prevention measures and accident prevention regulations as well as emergency routes at this site.
- The charging station must not be installed in zones at risk of explosion (EX environment); likewise, areas with special hazards (flooding, mudslides, avalanches, etc.) must be avoided.
- The charging station may only be installed in stationary applications at the prescribed installation heights.
- Install the charging station in such a way that charging cables do not overlay or cross any pedestrian paths.
- Do not install the charging station at locations where it is exposed to ammonia or ammonia gas (e.g. in or at stables).
- Do not install the charging station at locations where falling objects (e.g. hung-up ladders or automobile tires) could damage the charging station or the plug holder.
- The charging station must not be exposed to direct spray water (e.g. neighboring manual car wash facility, high-pressure cleaner, garden hose).
- The charging station should be protected against direct rain as far as possible to prevent icing, hail damage or similar.

- If possible, the charging station should be mounted protected from direct sunlight. Otherwise, with a combination of high ambient temperature and strong sunlight, the charging current specification may be temporarily reduced or the charging process may be switched off to protect the device from overheating.
- Observe the permissible ambient conditions (see "[21 Technical data](#)").

## 8.2 Required tools

The following tools are required for the installation:

- Drill bit suitable for the wall material (Ø8 mm for masonry or concrete)
- Screwdriver/bit Torx T25

## 8.3 Installation specifications and space requirement

### Installation specifications

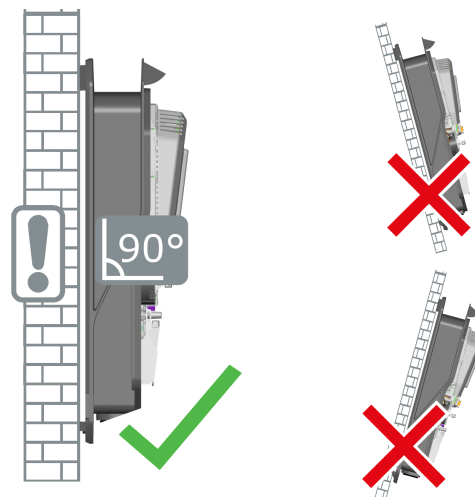

The charging station must be installed vertically, without any tilt, on a wall or floor-mounted column. Installation on the floor or on a ceiling is not permitted.

## Space requirement

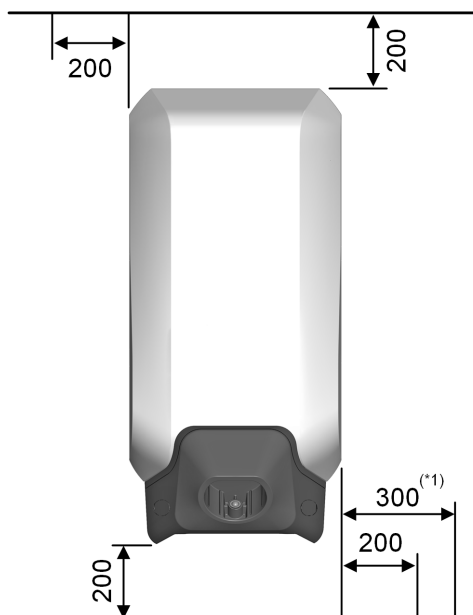

Fig. 8-1: Minimum distances in millimetres

When positioning the charging station and plug holder, sufficient space below for hanging the charging cable must be planned.

If several charging stations are installed adjacent to each other, a minimum spatial clearance to the side of the charging stations must be complied with.

### Information

- The plug holder of the charging station must be installed at a height between 50 cm and maximum 150 cm. Observe that national regulations can limit this height.  
For accessibility, installation of the plug holder for the charging station at a height between 85 cm and maximum 100 cm is recommended.
- The installation height of the charging station can also be higher. However, depending on the device variant, unhindered access to the RFID reader, touch button and optional display of the energy meter is necessary.
- \*1) For a device variant with an energy meter, a larger clearance on the right side is recommended to allow for the display to be read comfortably.

## 8.4 Preparing the charging station for installation

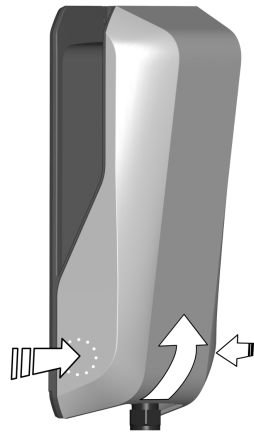

The charging station must be prepared for this before mounting. To do this, proceed as follows:

- 1) Push in slightly on the housing cover in the lower left and right area until the housing cover unlocks.
- 2) Lift the housing cover at the bottom, then remove it upward.



- 1) Remove the four Torx screws (1) of the protective cover.

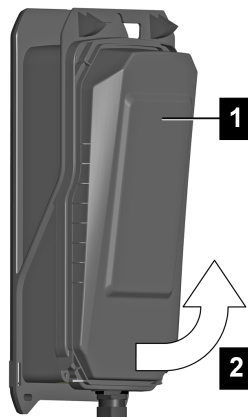

- 1) Lift the protective cover (1) at the bottom (2), then remove it upward.

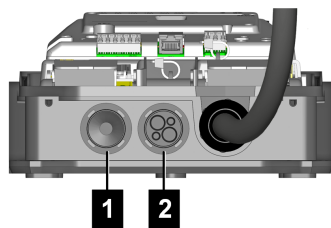

- Surface-mounted cable installation: Use cable entries on the underside!
- Flush-mounted cable installation: Use cable entries on the back side!

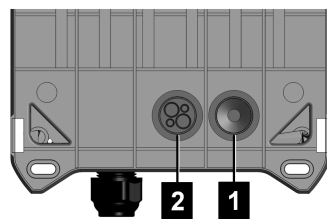

- 1 ... Cable entry for the supply line
- 2 ... Cable entry for control lines/Ethernet

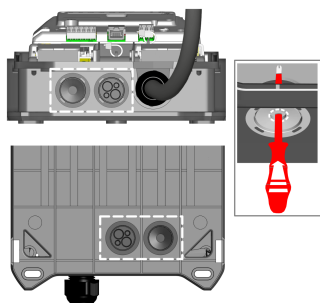

- 1) Place the charging station on a stable surface.
- 2) Push the seals of the required cable entries through carefully (e.g. with a suitable screwdriver).

The charging station is now ready for installation.

### Cable glands

As an alternative to the pre-mounted seals, cable glands can also be used (not included in the scope of delivery). If the installation requires strain relief, a cable gland must be used.



Recommendation:

- Progress® multiLAYER GRP plastic
- Manufacturer's item number: 1540.4.25
- Thread: M25x1.5
- Min./max. clamping range: 6.0 mm / 20.5 mm
- Tool size: 34 mm

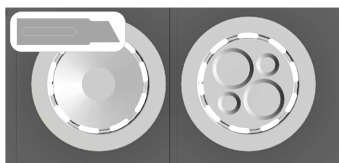

- 1) For the use of cable glands, the corresponding seals must be cut out of the charging station in a ring shape.
- 2) Ensure leak-tightness when inserting the cable gland.

### Preparing the optional substitute hole

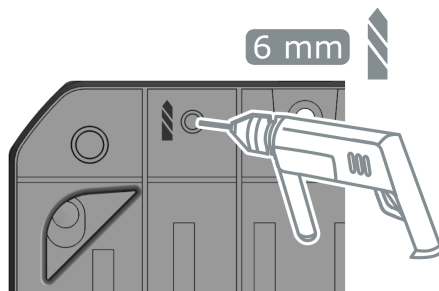

If use of the upper substitute hole is necessary, proceed as follows:

- 1) Drill the substitute hole into the housing at the marked spot on the back side.
- 2) Remove drilling dust and chips.

The substitute hole can now be used for installation.

## 8.5 Mounting the charging station

### Information

- If there are flush-mounted lines in the area of the upper mounting point, a **substitute hole position** is available. For using the substitute hole, a hole must be drilled into the housing of the charging station (see chapter "8.4 Preparing the charging station for installation").
- When mounting on a wooden wall, it is recommended to pre-drill the holes with a wood drill suitable for the fixing screws.

### Hole positions

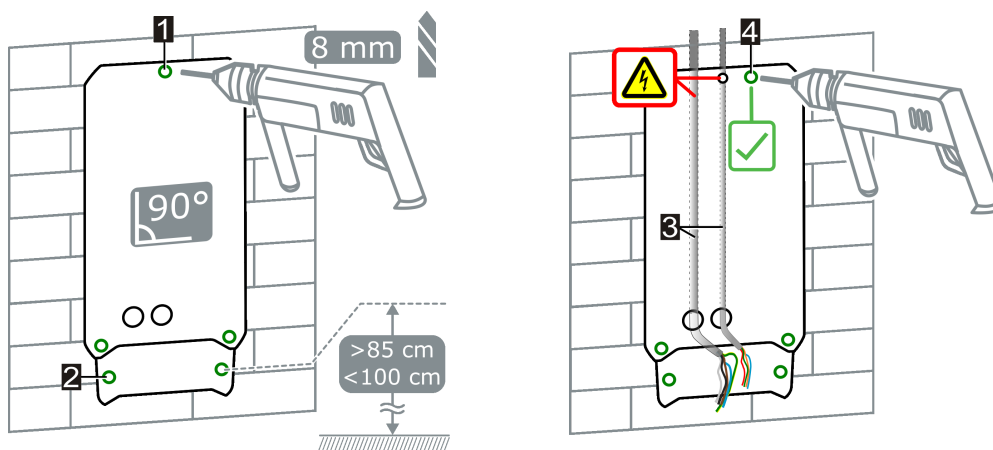

<b>1</b> ... Charging station mounting holes	<b>2</b> ... Plug holder mounting holes
<b>3</b> ... Flush-mounted cable routing (optional)	<b>4</b> ... Upper substitute hole position (marked on the back side of the charging station)

**Mounting the charging station**

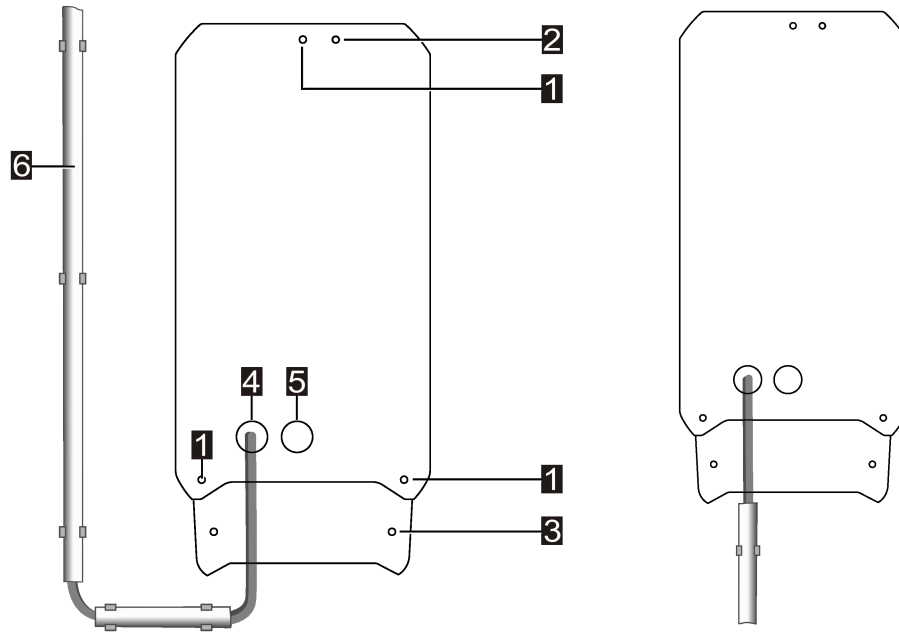

Fig. 8-2: Example: Mounting points and surface-mounted cable routing

<b>1</b> ... Charging station mounting holes	<b>2</b> ... Upper substitute hole position
<b>3</b> ... Plug holder mounting holes	<b>4</b> ... Supply line cable opening
<b>5</b> ... Control line cable opening	<b>6</b> ... Supply line with surface-mounted cable routing



**WARNING!**

**Electrical danger!**

Electric shock due to torn out supply line.

- When laying cables, ensure that the supply cable is strain-relieved by using appropriately laid protective piping and, if necessary, a cable gland or equivalent strain relief.

- 1) Mark the three drilled holes **(1)** using the drilling template at the designated location on the wall. Ensure horizontal alignment. If there is a flush-mounted line below the upper mounting point, the substitute hole position must be used.
- 2) If the plug holder is to be positioned directly beneath the charging station, also mark the two mounting holes for the plug holder **(2)**. The plug holder can be installed directly beneath or separately from the charging station. If mounted separately, it can also be used as a cable hanger.
- 3) Drill holes (Ø 8 mm) and, if necessary, insert anchors in the holes.
- 4) First, screw the screw in the upper mounting point approx. 2 cm.

- 5) **Connection cable from the rear:**  
Pull the connection cable through the prepared cable openings on the back side of the charging station, paying attention to leak-tightness!  
Hang the charging station on the upper screw (keyhole), position it and secure using the three mounting screws **(1)**.
- 6) **Connection cable from below:**  
Hang the charging station on the upper screw (keyhole), position it and secure using the three mounting screws **(1)**.  
Pull the connection cable through the prepared cable openings on the underside of the charging station, paying attention to leak-tightness!
- 7) Guide the supply line into the cable opening until the cable sheathing is visible in the connection area.
- 8) In case of surface-mounted cable routing, maintain a sufficiently large bending radius so that the plug holder under the charging station does not collide with the connection cables.
- 9) If the plug holder is positioned directly beneath the charging station, it may only be secured using the two mounting screws **(2)** after completing the installation. Otherwise, the housing cover can no longer be attached.

The charging station is mounted on the wall and ready for wiring.

## 8.6 Notes on cable routing

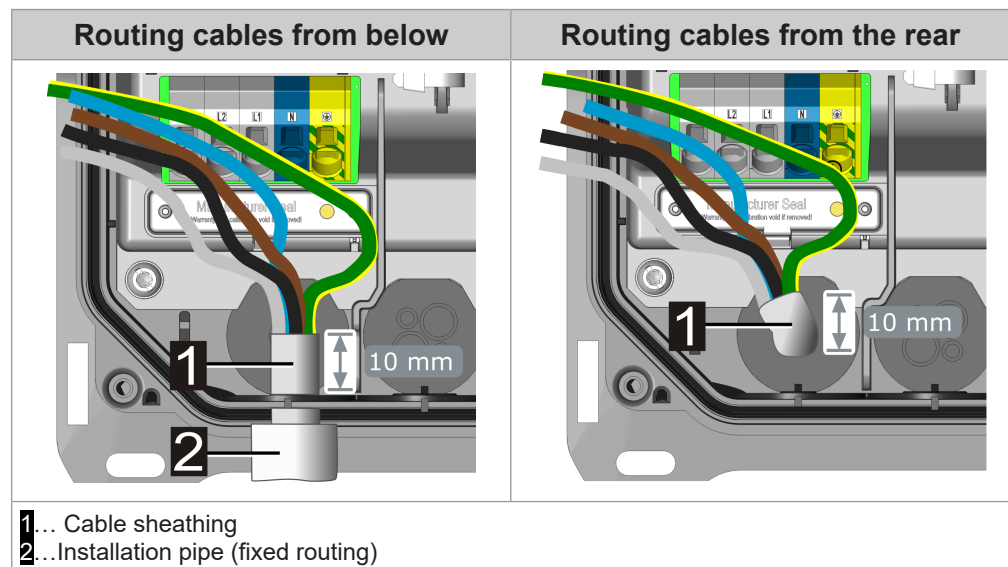

Note the following points during cable routing:

- At least **150 mm** must be stripped from the cable sheathing of the supply line.
- Enough supply line must be guided through the seal or optional cable gland so that at least **10 mm** of the cable sheathing is visible in the connection area.
- The seal must be in full contact with the cable sheathing.
- Make sure that the connection cables are inserted through the seals straight and without pressure to ensure tightness.

- An installation pipe or installation hose must not be guided through the seal or screwed into a cable gland.
- An appropriate diameter for an optional cable gland for the cable diameter used must be observed in order ensure tightness.
- Examine all cable passages for tightness. Any optional cable glands used must be properly installed and screwed sufficiently tightly, as otherwise water ingress can occur.

## 9 Electrical connections and wiring

### 9.1 Required tools

The following tools are required for the electrical installation:

- Screwdriver/bit Torx T25
- Slotted screwdriver with blade width of 3.0 mm for terminals when using braided wires or for opening supply terminals, if necessary.

### 9.2 Voltage zones

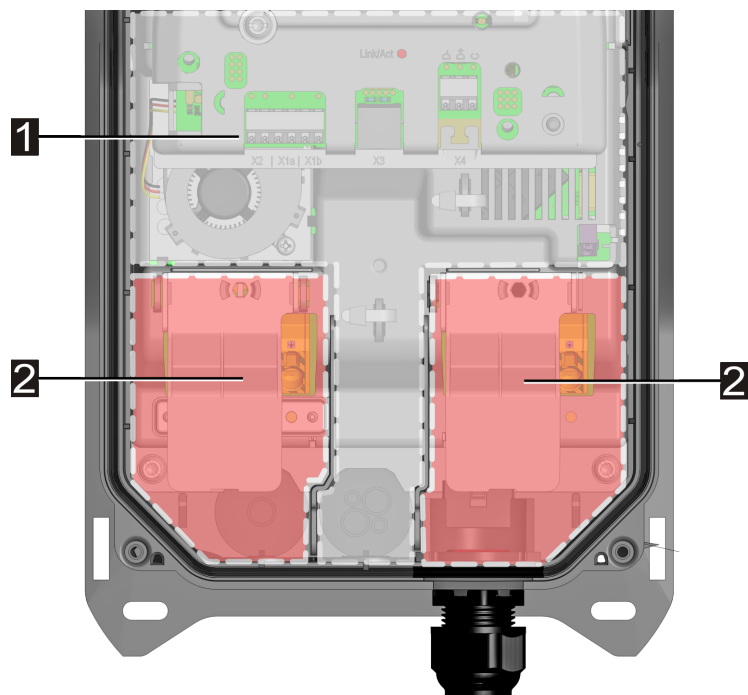

**1** ... Protective extra-low voltage zone

**2** ... Low-voltage zone

All control lines must be routed in the protective extra-low voltage zone, safely separated from the connection lines of the low-voltage zones.

### 9.3 Connecting the voltage supply

The charging station can have a 1-phase and (optional) 3-phase connection:

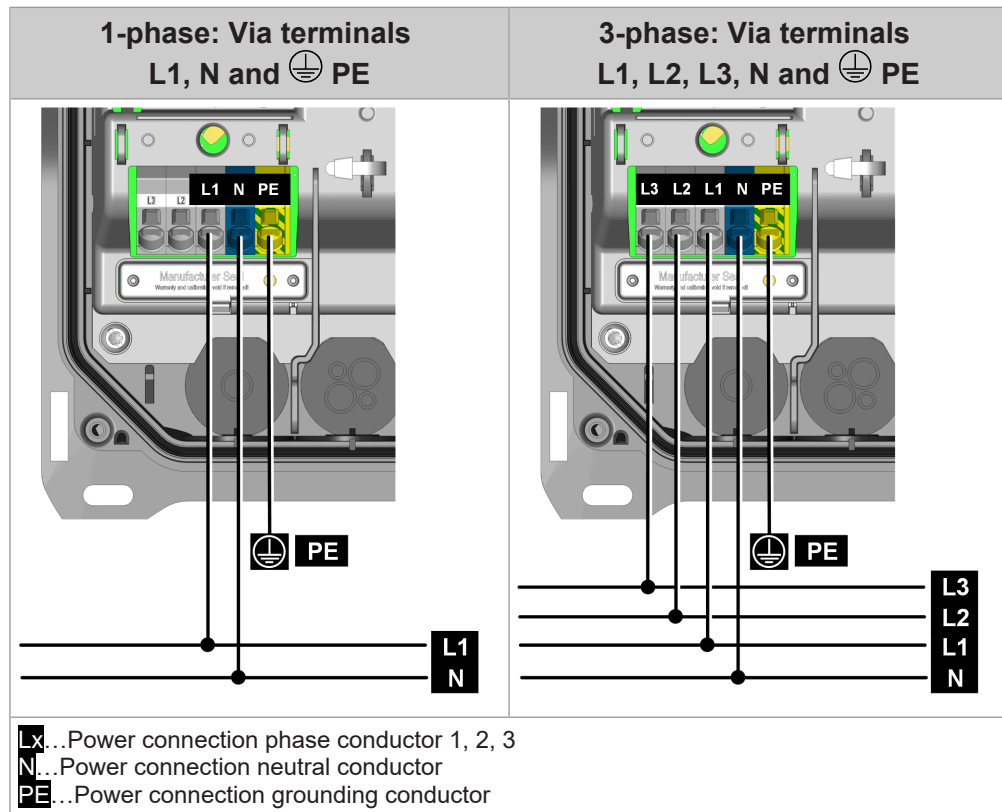

For the electrical connection to other network configurations, see "9.4 Electrical connection to special systems of AC power supply."

The supply terminals are designed as push-in spring terminals.

#### 9.3.1 Connection example - Cable entry from below

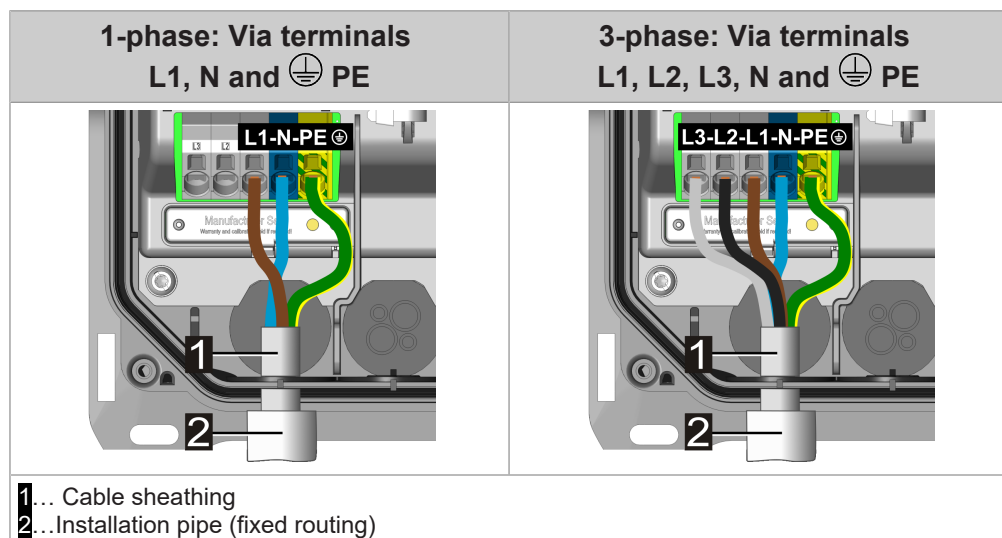

To connect the supply voltage, proceed as follows:

- 1) The cable sheathing of the supply line must extend into the charging station by at least **10 mm**.
- 2) Shorten the connector wires to **100 mm**. The protective conductor  (PE) must be longer than the other conductors by **130 mm!**  
The excess lengths of connector wires must not be routed in the area for the control lines. Safe separation must be ensured.
- 3) Strip **18 mm** of insulation from all connector wires.
- 4) Push all connector wires into the designated terminal openings of the push-in spring terminals as far as they will go. For fine stranded wires, it is recommended to open the spring terminals slightly by inserting a flat-head screwdriver.
- 5) Check that all connector wires are positioned securely.

The charging station is connected to the power supply.

#### Information

- There is an embossed stripping template on the protective cover as an installation aid.
- When connecting several charging points, it is recommended to swap the connection order to avoid grid asymmetries.

## 9.4 Electrical connection to special systems of AC power supply

### Information

*The charging station can in principle be connected to TN, TT and IT systems of AC power supply networks. Pay attention to the restrictions of your vehicle manufacturer.*

We recommend connecting the charging station in 230 V delta networks without an upstream transformer only in single phase. A three-phase connection in delta networks should only take place with an upstream transformer ("triangle-to-star converter").

### Connection diagram

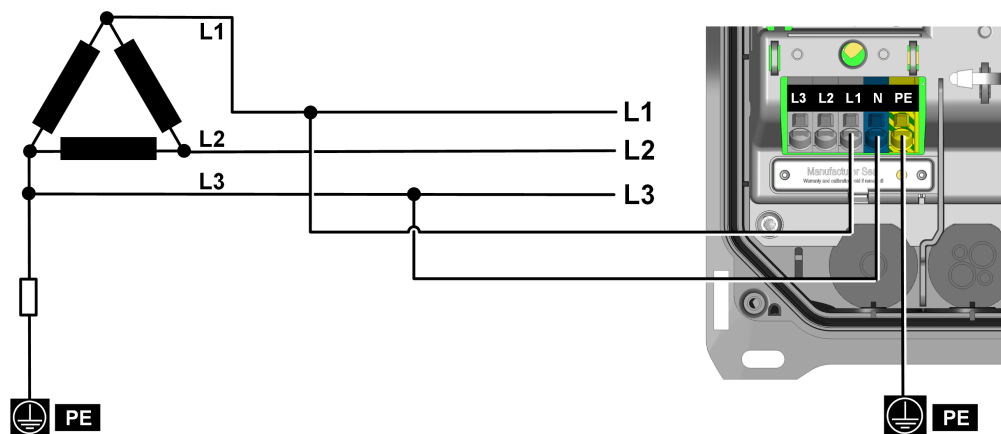

Fig. 9-3: Connection to a three-wire IT system with 230 V

### Caution

#### Risk of damage due to defective surge arrester!

The conductor that has the direct or high-resistance connection to the PE potential must always be connected to the "N" terminal (see connection diagram for example).

### 9.5 Connection overview of the application module

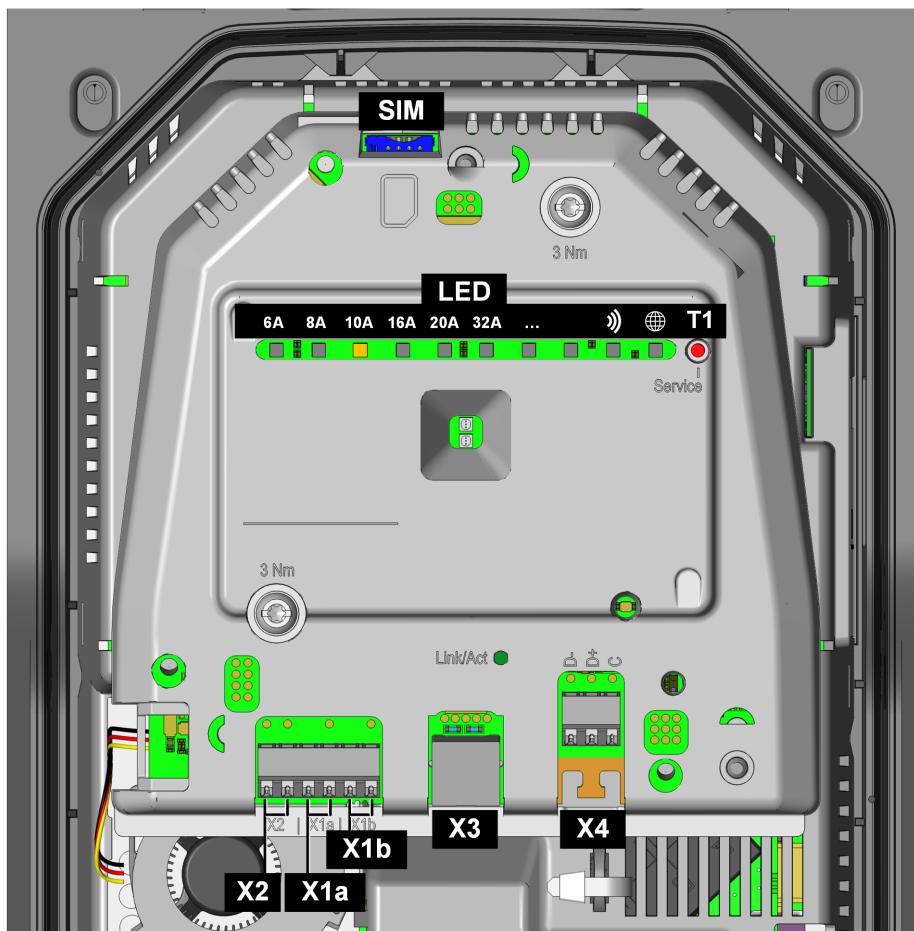

<b>X1a</b> ... Switch contact input 1	<b>X1b</b> ... Switch contact input 2
<b>X2</b> ... Switch contact output	<b>X3</b> ... LAN network connection (RJ45)
<b>X4</b> ... RS485 interface	<b>T1</b> ... Service key
<b>LED</b> ... Status display (LED bar)	<b>SIM</b> ... SIM card slot (option)



**WARNING!**

**Risk of electric shock and fire hazard!**

Only SELV/PELV voltages and circuits that have a safe separation from hazardous voltages (for example, sufficient insulation) are permitted to be connected to terminals [X1] through [X4] (switch contact inputs, switch contact output, LAN port and RS485 port).

## 9.6 Switch contact inputs [X1a] / [X1b]

The switch contact inputs are intended to be used with an external floating switch contact. Using these inputs, operation of the charging station can be controlled by external systems (e.g. by external key-operated switch, house control, photovoltaic system, ripple control receiver, etc.).

The switch contact inputs are not isolated from internal electronics of the charging station. To read in the state, the external switch contact is loaded with 12 V DC PELV voltage and 2,5 mA.

The terminals are designed as push-in spring terminals.

Activation and configuration of this function takes place using KEBA eMobility App.

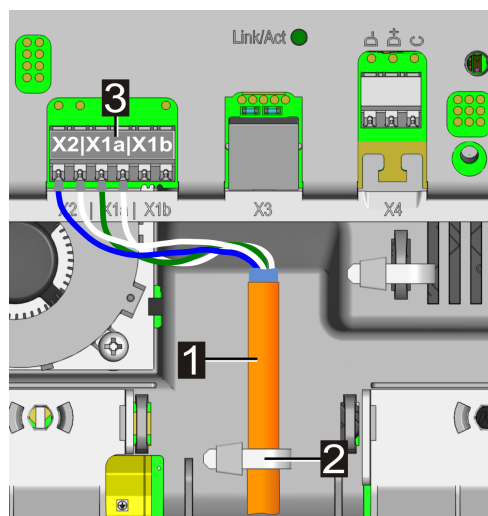

<b>1</b> ... Control line	<b>2</b> ... Cable tie (strain relief)
<b>3</b> ... Connection terminals (switch contact output / switch contact inputs)	

### Connection diagram (example of X1a)

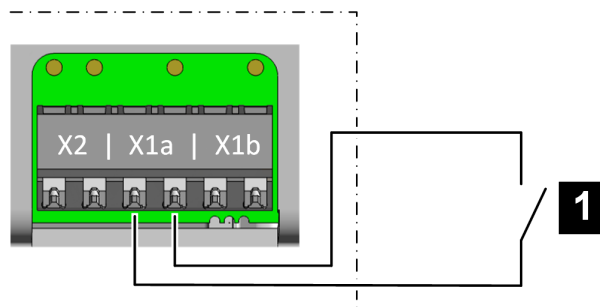

<b>X1x</b> ... Switch contact input of the charging station
<b>1</b> ... External floating switch contact

**Possible settings at the charging station**

Parameter	Setting
X1x switch contact input activated	ON/OFF
X1x switch contact input function	Depending on the desired logical function: <ul style="list-style-type: none"> <li>• Charging / No charging</li> <li>• Max. charging / reduced charging</li> <li>• Authorization bypass</li> <li>• Ignore PV using X1 (charging boost)</li> </ul>

**Example: Use as enable input**

Parameter	Setting
X1x switch contact input activated	ON
X1x switch contact input function	<ul style="list-style-type: none"> <li>• Charging / No charging</li> </ul>

The charging station then behaves as follows:

Switch contact input [X1x]	State
Open	Charging station locked
Closed	Charging station ready for operation

In addition, starting a charging process using an enable input is dependent on the RFID authorization. The table shows the conditions under which charging is enabled.

RFID function	Input X1x function	Description
Off	Off	Permanent charging enabled – charging is possible at all times.
Off	On	Charging enabled only when X1x is closed.
On	Off	Charging enabled only when RFID authorization is correct. Charging is not possible without an RFID card.
On	On	<b>X1x function "Charging / No charging":</b> Charging enabled when X1x is closed <b>AND</b> RFID authorization is correct.  <b>X1x function "Authorization bypass":</b> Charging enabled when X1x is closed <b>OR</b> RFID authorization is correct.
On...Function activated in the app / Off...Function deactivated in the app		

## 9.7 Switch contact output [X2]

The switch contact output is a floating relay contact and can be used as a charging status display, for example, or for main relay monitoring.

The switch contact output for SELV/PELV voltages has 1500 V AC isolation from the internal electronics.

The terminals are designed as push-in spring terminals.

Activation and configuration of this function takes place using KEBA eMobility App.



### WARNING!

#### Risk of electric shock!

Supply the terminal for the switching contact output [X2] exclusively from a voltage source that has SELV/PELV protective extra-low voltage.

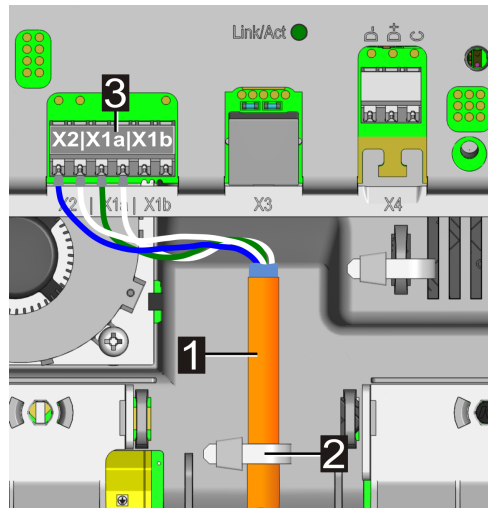

<b>1</b> ... Control line	<b>2</b> ... Cable tie (strain relief)
<b>3</b> ... Connection terminals (switch contact output / switch contact inputs)	

### Connection diagram

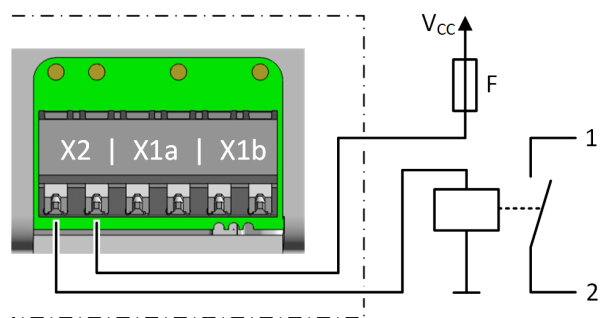

<b>V<sub>cc</sub></b> ... Protective extra-low voltage	<b>F</b> ... Current-limiting equipment (≤0.5 A)
--	--

### Possible settings at the charging station

Parameter	Setting
X2 switch contact output activated	ON/OFF
X2 switch contact output function	Depending on the desired logical function: <ul style="list-style-type: none"> <li>• Signaling availability</li> <li>• State of charge signaling</li> <li>• Main relay monitoring signaling</li> </ul>

### Example: Use for availability display

Parameter	Setting
X2 switch contact output activated	ON
X2 switch contact output function	Signaling availability

The charging station then behaves as follows:

Switch contact output [X2]	State
Open	Charging station is available. Charging station is ready for operation and no vehicle is connected.
Closed	Charging station is not available. Vehicle is connected, charging station not in operation or faulty.

### Example: Use for state of charge display

Parameter	Setting
X2 switch contact output activated	ON
X2 switch contact output function	State of charge signaling

The charging station then behaves as follows:

Switch contact output [X2]	State
Open	Charging station ready for operation and no vehicle is connected or vehicle is connected and not being charged.
Closed	Vehicle is connected and charging.

### Example: Monitoring the internal main relay

Parameter	Setting
X2 switch contact output activated	ON
X2 switch contact output function	Main relay monitoring signaling

The charging station then behaves as follows:

Switch contact output [X2]	State
Open	No error.
Closed	Error - The switch contacts of the installed main relay are stuck.

### 9.7.1 Connection example of switch contact output X2 - Higher-level disconnect solution

The switch contact output can also be used to de-energize the charging station with a higher-level disconnect solution in the event of error.

Activation and configuration of this function takes place using KEBA eMobility App.

#### Connection diagram

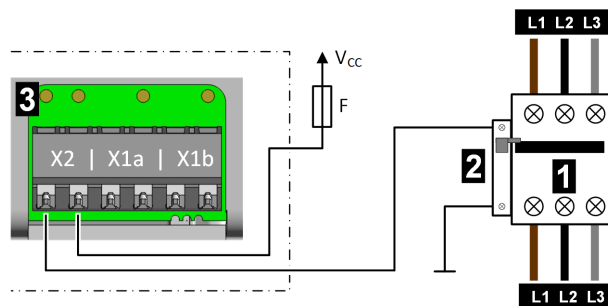

<b>1</b> ... Circuit breaker of the charging station	<b>2</b> ... Remote trigger (shunt trip coil)
<b>3</b> ... Switch contact output X2	<b>F</b> ... Current-limiting equipment ( $\leq 0.5$ A)
<b>V<sub>cc</sub></b> ... Protective extra-low voltage (SELV/PELV)	

#### Necessary settings at the charging station

Parameter	Setting
X2 switch contact output activated	ON
X2 switch contact output function	Main relay monitoring signaling

## 9.8 Network connection (LAN) [X3]

The network connection establishes a wired connection to an Ethernet network (LAN).

The floating network connection is executed as a RJ45 socket.

Activation and configuration of this function takes place using KEBA eMobility App.



### WARNING!

#### Risk of electric shock!

In extended systems, a transient current flowing through the shielding can lead to hazards when work is being done on the data lines. Countermeasures must be agreed on with the persons responsible for building services.

### Connection diagram

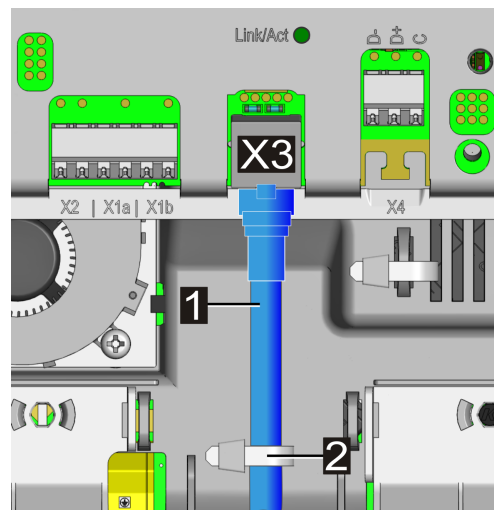

<b>1</b> ... Network cable	<b>X3</b> ... Network connection
<b>2</b> ... Cable tie (strain relief for control lines)	

To connect the network cable, proceed as follows:

- 1) Thread the network cable through the appropriate cable opening for control lines, paying attention to tightness.
- 2) Attach a suitable RJ45 connector to the network cable. Observe the following information for the RJ45 connector.
- 3) Connect the network cable to the network port.
- 4) Fasten the network cable using a cable tie as shown (strain relief).

The network cable is connected.

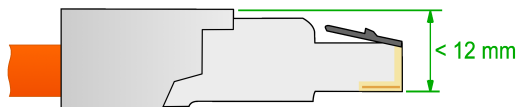
**Note on (field-attachable) RJ45 connectors****Caution****Risk of damage!**

The RJ45 connector used must not exceed the specified height according to the drawing! Otherwise, the circuit board can be damaged when the protective cover is closed.

**Network connection status LED**

The "Link/Act" status LED for the network interface is located above the RJ45 socket.

"Link/Act" status LED	Description
Off	No connection to the network
Lights up green	Connection to the network (Link)
Flashes green	Data transfer in progress (Activity)

## 9.9 RS485 interface\* [X4] (for external energy meter)

The RS485 interface is used for communication with an external energy meter (Modbus RTU-compatible).

\*)... Function will be made available with a later software update.

The RS485 interface of the charging station is potential-free.

For details on integrating external energy meters, refer to the chapter "[14.1 Integration of an external energy meter.](#)"

Activation and configuration of this function takes place using KEBA eMobility App.

The terminal is designed as a push-in spring terminal.

### Bus cabling requirements

- A suitable, shielded bus cable must be used.
- The bus cable must not be used for additional applications (e.g. switch contact inputs or switch contact output).
- For energy meters, the shared port (C/Common) for the bus connection must be connected with the ground potential (PE).
- The charging station has integrated AC termination for the bus line and therefore must be located at the start or end of the bus cabling. The opposite end of the bus cabling must also be terminated with a 120 ohm resistor.

### Factory setting of the RS485 interface

Speed:	9600 Bd, 14400 Bd 19200 Bd (default) 38400 Bd, 57600 Bd, 115200 Bd
Data frame:	1 start bit, 8 data bits, no parity, 1 stop bit
Line polarization:	Yes (fixed)
Bus node type:	Master
Bus address:	configurable
Bus termination:	Yes

## Connection diagram

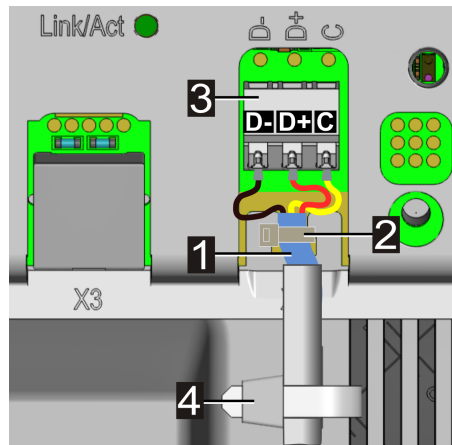

<b>1</b> ... Cable shield	<b>2</b> ... Cable tie (shielding)
<b>3</b> ... RS485 port D- / D+ / C	<b>4</b> ... Cable tie (strain relief)

Designation of the terminal	Modbus RTU designation	EIA/TIA-485 designation
D-	D0	A
D+	D1	B
C	Common	C

To connect the RS485 bus cable, proceed as follows:

- 1) Thread the bus cable to the RS485 port through the appropriate cable opening for control lines.
- 2) Strip 50 mm of the connection cable. Strip an additional 10 mm of insulation from the cable sheathing so the cable shielding is exposed. Also remove any plastic film, if present.
- 3) Fasten the cable shielding with a cable tie to the T-section of the circuit board (shield connection).
- 4) Strip 10 mm of insulation from the three connector wires D- / D+ / C and connect to the RS485 port. With flexible connector wires, also use core-end sleeves.
- 5) Fasten the bus cable to the housing using a cable tie.  
The excess length of the bus cable must be routed in the center in the designated area so that safe separation from the supply line and charging cable is guaranteed.

The bus cable is connected.

## 9.10 Switching on the power supply

The power supply can be switched on after successful connection of all necessary lines.

- 1) Position the protective covers for commissioning the charging station.
- 2) Switch on the corresponding cut-off device for the power supply in the upstream electrical installation.

## 10 Wireless connections

### 10.1 WLAN connection

The WLAN module establishes a wireless connection to a local network (LAN).

Activation and configuration of this function takes place using KEBA eMobility App.

Ensure a connection of sufficient quality to your WLAN access point to guarantee a reliable connection. Walls or other obstacles can reduce the range of the wireless signal significantly.

### 10.2 Mobile network communication (LTE option)

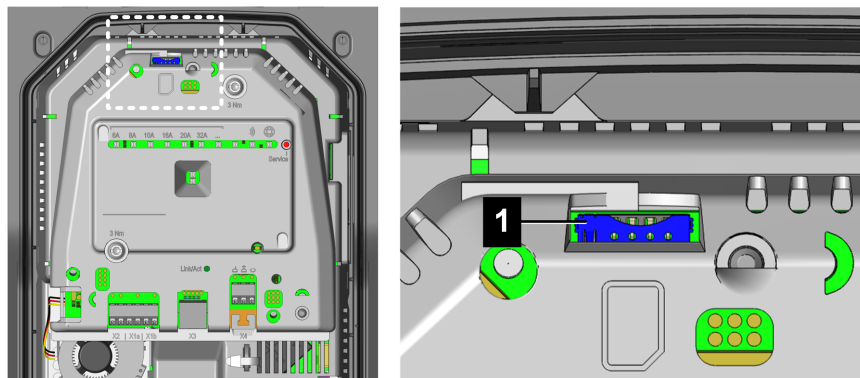

1 ... SIM card slot

In order to be able to communicate with a higher-level OCPP backend in a charging network, the charging station can optionally be equipped with a mobile network interface.

To use the mobile network function, a suitable SIM card (see "[21 Technical data](#)") must be inserted in the SIM card slot.

Activation and configuration of this function takes place using KEBA eMobility App.

The access data of the mobile network provider must be entered using KEBA eMobility App (e.g.: SIM PIN).

### 10.2.1 Inserting the SIM card

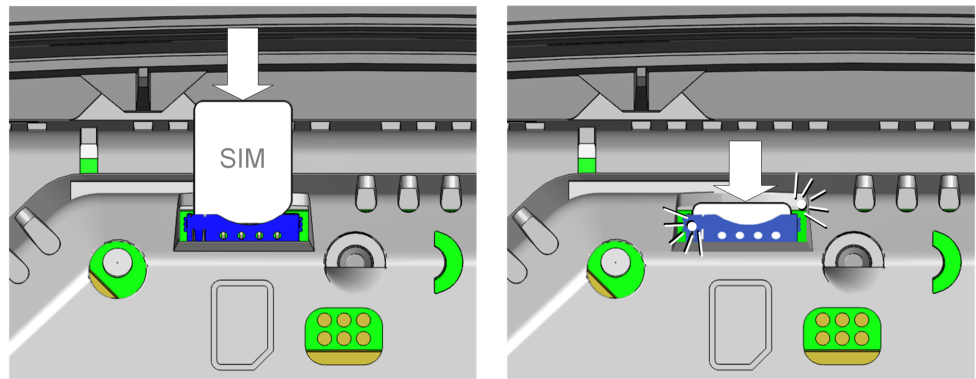

The SIM card can also be inserted in the switched-on operating state.

- 1) Lightly press the SIM card into the card slot from above until the mechanism locks in the end position.

The SIM card is inserted.

### 10.2.2 Removing the SIM card

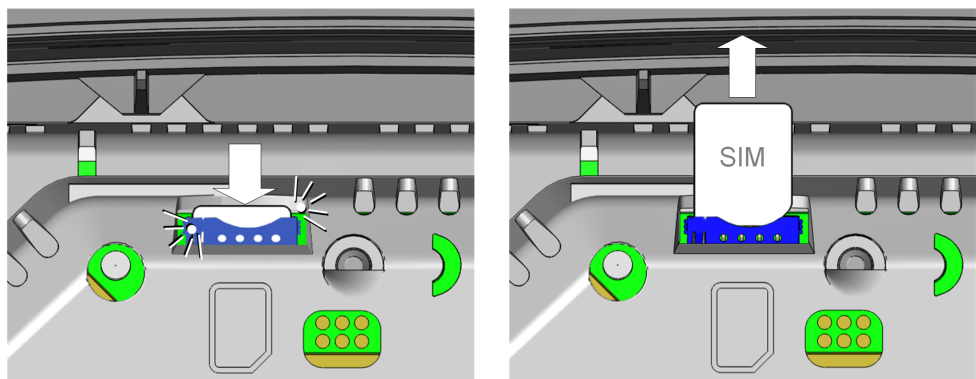

The SIM card can also be removed in the switched-on operating state.

- 1) By lightly pressing the SIM card with your finger, the mechanism is activated and the SIM card is ejected.
- 2) Remove the SIM card upward.

## 11 Configuration

There are several methods for configuring the charging station. Overview:

### Basic electrical configuration directly at the device

After the charging station has been put in installation mode, the Service key can be used (independent of KEBA eMobility App) to set the charging current limit.

### Basic electrical configuration and parameterization using the app

After the device has been connected with KEBA eMobility App and put in installation mode, the charging current limit and other settings can be parameterized according to the local connection requirements using the "Installer" role and **Installer PWD**. These settings are protected against changes by the following measures:

- Necessity to connect using the app and corresponding **PIN**.
- Password protection of installation mode with **Installer PWD**.
- Activation of installation mode only possible using **Service** key on switched-on device (tool necessary to access this area).

### Operation and extended configuration using the app

After the charging station has been connected with KEBA eMobility App, extended settings (network, interfaces, etc.) can be configured at the charging station using the "User" role and **User PWD**.

## 11.1 Activating/deactivating installation mode

For the basic electrical configuration and parameterization according to the connection requirements, the charging station must be set in installation mode.

### Activating installation mode

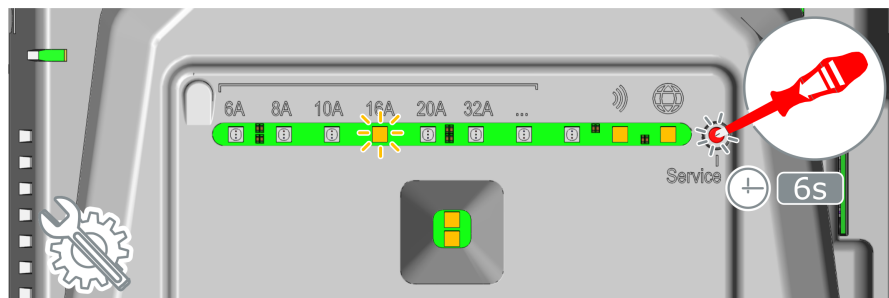

- 1) If necessary, remove the housing cover and protective cover of the charging station.
- 2) If switched off, switch on the power supply of the charging station.
- 3) Press and hold the recessed **Service** key with a screwdriver for **6 seconds**. If deactivated, this also temporarily switches on the Bluetooth® function.

Signaling: The value for the charging current limit currently set flashes orange and the smart charging symbol lights up orange.

Installation mode is activated. Simplified configuration of the charging current limit using the Service key or extended configuration of the charging station using KEBA eMobility App can now be performed.

### Deactivating installation mode

Installation mode can be ended as follows:

- Press the **Service** key for **6 seconds**.
- Press the corresponding key in KEBA eMobility App.
- Installation mode is ended automatically when the charging station is switched off or after 30 minutes.

## 11.2 Basic electrical configuration directly at the device

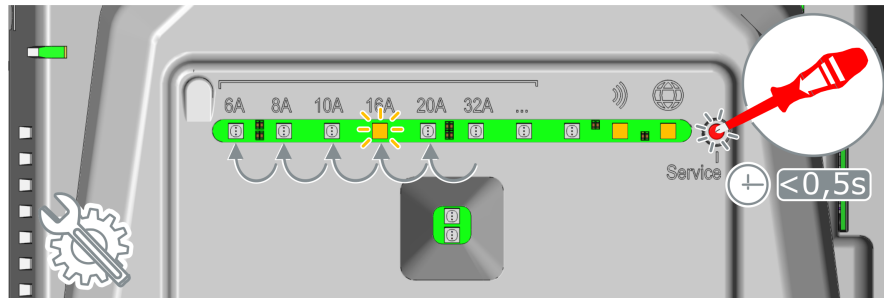

**xA** ... Charging current limit (6A, 8A, 10A, 16A, 20A, 32A)

**[...]** ... Custom charging current limit has been set in the app

During basic electrical configuration directly at the charging station, the **charging current limit** can be set using the **Service** key.

### Showing the current configuration setting

- 1) Press the **Service** key briefly.

The current setting of the charging current limit as well as the Bluetooth® and backend status are shown for 5 seconds (for details, see "[11.7 Displays during configuration](#)"). Example:

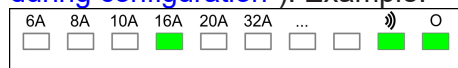

### Adjusting the charging current limit

To adjust the charging current limit, proceed as follows:

- 1) Activate installation mode (see "[11.1 Activating/deactivating installation mode](#)").
- 2) Press the **Service** key briefly to set the desired charging current limit to one of the pre-defined ampere values one step at a time:  
**6A, 8A, 10A, 16A, 20A or 32A.**  
An LED lights up beneath the set charging current limit. If a custom value was set for the charging current limit using KEBA eMobility App, the LED for **[...]** lights up.
- 3) Deactivate installation mode (see "[11.1 Activating/deactivating installation mode](#)").

The charging current limit is set.

#### Information

*When setting the charging current limit, the fuses, maximum available capacity for the charging point, specifications of the energy supplier, etc. must be taken into account.*

### 11.3 Establishing an app connection via Bluetooth®

For the initial use of the KEBA eMobility App and for configuring or operating the charging station, proceed as follows:

- 1) Install the KEBA eMobility App on your mobile device.
- 2) Switch on the mobile device's Bluetooth® function.
- 3) The power supply for the charging station must be switched on. The integrated Bluetooth® function is activated by default upon delivery. If the Bluetooth® function is deactivated, it can be activated using a LAN/WLAN connection or by activating installation mode (directly at the device).
- 4) Be within a distance of maximum 10 m from the charging station to enable wireless communication.
- 5) Open the KEBA eMobility App.
- 6) Select the corresponding charging station or add a new charging station using the **[+]** button.
- 7) For a newly added charging station, enter the **PIN** of the charging station (see sticker on the back side of the included short manual).
- 8) Select the **"User"** or **"Installer"** role and enter the corresponding User PWD/Installer PWD password (see sticker on the back side of the included short manual).

The connection to the charging station is established.

### 11.4 Basic electrical configuration and parameterization using the app

Using KEBA eMobility App, the basic electrical configuration and parameterization can be performed by selecting the **"Installer"** role in installation mode. To do this, proceed as follows:

- 1) Activate installation mode (see "[11.1 Activating/deactivating installation mode](#)").
- 2) Select the charging station in KEBA eMobility App (see "[11.3 Establishing an app connection via Bluetooth®](#)").
- 3) Select the **"Installer"** role and enter the **Installer PWD** (see sticker on the back side of the included short manual) to receive the authorization to parameterize the corresponding configuration values.
- 4) Set the desired configuration parameters according to the following overview.

#### Important configuration parameters

Using KEBA eMobility App, the following settings can be adjusted, depending on the device variant:

Parameter	Description	Setting
Charging current limit	Maximum charging current that can be provided to a vehicle.	6 A – 32 A (1 A steps)
Unbalanced load	Maximum current for one-/two-phase charging of electric vehicles. This may be required by network connection regulations.	6 A – 32 A (1 A steps) 0 = deactivated

Parameter	Switch contact inputs X1a / X1b	Setting
X1x activated	Activates the switch contact input.	OFF ON
X1x function	<p>Defines the functionality that is triggered by a state change of input X1x.</p> <ul style="list-style-type: none"> <li> <b>Charging / No charging:</b>                      If the input =0 (open), charging is not possible. Charging is only possible via an external switch contact.                 </li> <li> <b>Maximum charging / reduced charging:</b>                      If the input =0 (open), only reduced charging is possible. A value for the reduced charging current must be selected.                 </li> <li> <b>Authorization bypass:</b>                      If the input =1 (closed), the charging session will start in any case.                 </li> <li> <b>Ignore PV using X1:</b>                      If the input =1 (closed), the charging current specification is ignored by PV optimization and maximum charging current is used for charging (charging boost).                 </li> </ul>	Charging / No charging  Max. charging / reduced charging  Authorization bypass  Ignore PV using X1

Parameter	Switch contact output X2	Setting
X2 activated	Activates the switch contact output X2.	OFF ON
X2 function	<p>Defines under which circumstances the switch contact output switches.</p> <ul style="list-style-type: none"> <li> <b>Signaling availability:</b>                      Switches the output as soon as a vehicle is connected to the charging station.                 </li> <li> <b>State of charge signaling:</b>                      Switches the output if a connected vehicle is being charged.                 </li> <li> <b>Main relay monitoring signaling:</b>                      Switches the output if stuck main relay contacts are detected and the internal main relay can no longer be actuated.                 </li> </ul>	Signaling availability  State of charge signaling  Main relay monitoring signaling

### Deactivating installation mode

- 1) Deactivate installation mode (see "[11.1 Activating/deactivating installation mode](#)").

## 11.5 Operation and extended configuration using the app

Using KEBA eMobility App, the "User" role can be selected to perform extended configuration. To do this, proceed as follows:

- 1) Select the charging station in KEBA eMobility App (see "[11.3 Establishing an app connection via Bluetooth®](#)").
- 2) Select the "User" role and enter the **User PWD** (see sticker on the back side of the included short manual) to receive the authorization to parameterize the corresponding configuration values.
- 3) Set the desired configuration parameters according to the following overview.

### Important configuration parameters

Using KEBA eMobility App, the following settings can be adjusted, depending on the device variant:

Variant-dependent interfaces	
Ethernet (LAN)	Depending on the device variant, different interfaces are available which can be activated, deactivated and parameterized.
Bluetooth®	
RS485	
WLAN	
Mobile network	
RFID	For charging stations with the corresponding function, RFID card management can be performed using the app.
Touch button	For charging stations with the corresponding function, the touch button function can be performed using the app.

## 11.6 Activating/deactivating Bluetooth®

### Showing the Bluetooth® status

To show the current Bluetooth® status on the charging station, have an electrician proceed as follows:

- 1) Press the Service key once briefly. The configuration is then shown on the LED bar for 5 seconds:



#### Bluetooth® is activated:

- LED lights up green under the corresponding display.

#### Bluetooth® is deactivated:

- LED is dark under the corresponding display.

### Deactivating Bluetooth®

The Bluetooth® function integrated into the charging station is activated by default and can be deactivated as needed using KEBA eMobility App.

- 1) Navigate to the "Settings" in the app and follow the corresponding menu items.

#### Information

*If the Bluetooth® function is deactivated, it can only be reactivated via a functioning LAN/WLAN connection or using installation mode (directly at the device).*

### Activating Bluetooth®

There are two options for activating the Bluetooth® functions of the charging station:

- Bluetooth® can be reactivated using KEBA eMobility App if the charging station is integrated in the network via LAN or WLAN. Navigate to the "Settings" in the app and follow the corresponding menu items.
- Press and hold the **Service** key for **3 seconds** to permanently activate the Bluetooth® function of the charging station.

## 11.7 Displays during configuration

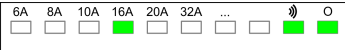
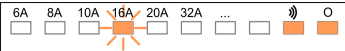
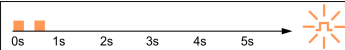
LED bar	Description
 <p data-bbox="459 421 783 562">Parameter illuminated green / Smart charging symbol illuminated green</p>	<p data-bbox="826 416 1450 499">If the Service key is pressed once briefly, the current configuration is shown on the LED bar for 5 seconds (see <a href="#">"11.2 Basic electrical configuration directly at the device"</a>).</p>
 <p data-bbox="459 707 783 790">Parameter flashing orange / Smart charging symbol illuminated orange</p>	<p data-bbox="826 645 1425 728">Installation mode was activated. The charging current limit can be set on the device or with the app (see <a href="#">"11.1 Activating/deactivating installation mode"</a>).</p>
 <p data-bbox="459 938 746 967">Flashing orange (2x short)</p>	<p data-bbox="826 860 1422 913">Installation mode was ended using the Service key and settings have been saved.</p>

The ampere values shown in the illustrations are printed on the housing of the charging station.

## 12 Commissioning

### 12.1 Perform safety checks

Before commissioning, check the effectiveness of the safety measure(s) of the system according to the nationally applicable regulations as well as IEC 60364.

Electrical systems or devices must be checked before commissioning the system or device. It is essential that all conditions for the safety measures are observed during installation.

- Checks must be performed according to the national regulations. At least the following checks must be performed:
  - Continuity of the connections of the protective conductor
  - RCD trigger current, triggering time, etc.
  - 6 mA detection device (trigger current and triggering time)
  - Visual inspection (damage to the product)
- The measurement devices must comply with the national regulations!
- The measurement results are to be documented. A test report is to be created and saved before the check.

#### Information

- The tripping characteristics of the internal DC residual current monitoring is based on the product-specific standard IEC 62955. According to this standard, a trigger delay of up to 10 seconds is permitted. This circumstance may result in a negative evaluation for conventional test settings for type B residual current circuit breakers. Here, special test settings are to be used for EVSE (Electric Vehicle Supply Equipment).
- State-of-the-art testing devices allow for measurement of the loop impedance without triggering a fault current device. This enables the measurement to take place using a vehicle simulator in the charging state.

## 12.2 Mounting covers / Sealing

To be able to operate the charging station safely, all covers must be attached as described.

### Mounting the terminal cover

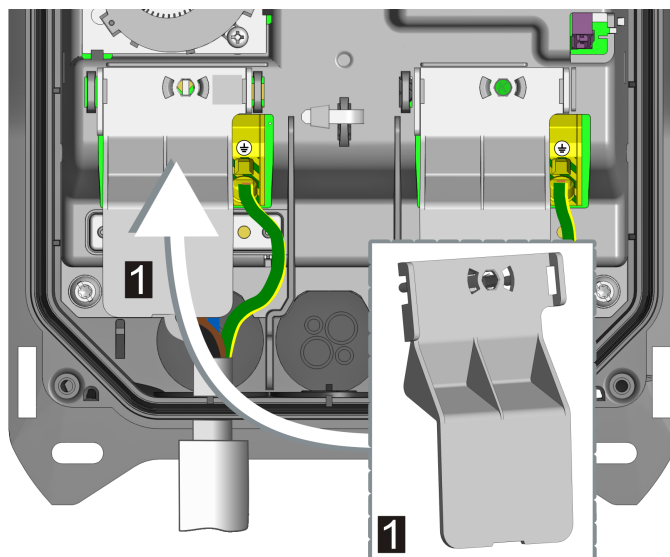

**1** ... Terminal cover

To mount the terminal cover, proceed as follows:

- 1) Insert the supplied terminal cover over the terminal block of the supply line.

The terminal cover is installed.



### **WARNING!**

#### **Risk of electric shock!**

A missing terminal cover can cause an electrical hazard in event of error (conductor has come loose from the terminal)!

- Always attach the terminal cover to guarantee safe separation between hazardous voltages and touchable voltages.

### Mounting the protective cover

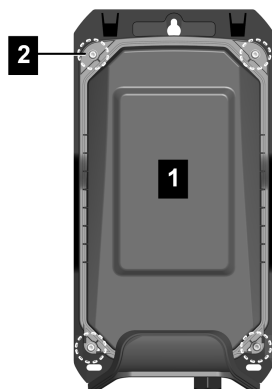

To mount the protective cover, proceed as follows:

- 1) Position the protective cover (1) on the housing. The protective cover must be positioned properly to guarantee leak-tightness of the device.
- 2) Tighten the protective cover with the four Torx screws (2) to 3 Nm.

The protective cover is installed.

### Sealing the protective cover

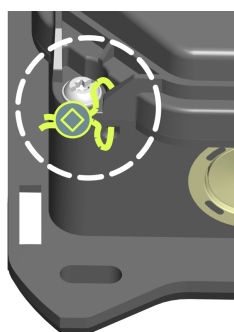

The lead seal of the protective cover makes unauthorized access to the interior of the device visible. This secures access to the power supply connection, basic electrical settings and changes to the components, among other things.

As needed, a lead seal can be implemented on one of the two lower mounting points of the protective cover.

### Fitting the housing cover

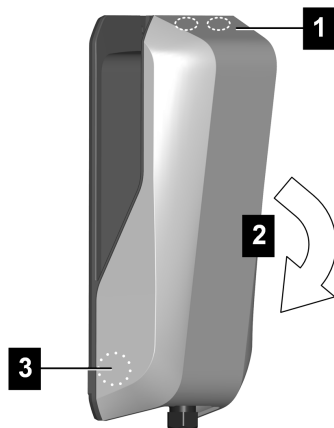

To fit the housing cover, proceed as follows:

- 1) Hook in the housing cover at the top (1) and close it downward (2). The housing cover must glide into the guides without considerable resistance. The housing cover must be correctly seated in the housing guide on all sides and snap in on the left and right in the lower area (3).

The housing cover is fitted.

## 12.3 Mounting the plug holder

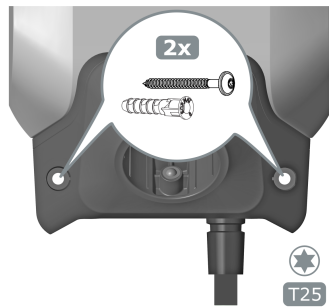

To mount the plug holder, proceed as follows:

- 1) Position the plug holder as desired and tighten it using the supplied anchors and screws or using suitable installation material that is appropriate for the subsurface.



- 2) Insert the two covering caps into the openings of the plug holder.

The plug holder is mounted.

## 13 RFID authorization

Certain device variants are equipped with an RFID reader, which enables the authorization of a charging process with RFID cards in accordance with ISO 14443 and ISO 15693. Activated RFID authorization means that a charging session can only be started by holding up a taught-in RFID tag.

Activation and configuration of this function takes place using KEBA eMobility App.

### Management through the charging station

For a charging station without a higher-level OCPP backend, all RFID cards must be taught in and saved locally at the charging station. Up to 1000 RFID cards can be stored.

RFID cards are managed using KEBA eMobility App or via the optional KEBA eMobility Portal.

### Management through the OCPP backend

If the charging station is connected to a higher-level OCPP backend, RFID cards are managed using the OCPP backend. Any number of RFID cards can be stored. It is not possible to teach in the RFID cards directly at a charging station.

The first 1000 RFID cards taught in to the OCPP backend are transferred to the charging station where they are stored locally. This enables charging sessions to be authorized even if the connection fails temporarily. In case of a connection failure, authorization requests, depending on the authorization mode, are compared to the locally stored RFID cards.

### 13.1 Authorization modes

The authorization modes described below are available if the authorization function has been activated. As a rule, the following methods are available for authorization:

- OCPP backend (KEBA eMobility Portal)
- OCPP backend (of other compatible manufacturers)
- Local authorization (without OCPP backend)

#### Authorization with OCPP backend (with connection)

This defines which storage location an authorization request is to be compared to.

Mode	Description
<b>First local</b>	The authorization request is first compared to the locally stored RFID cards stored at the charging station. If the RFID card is not stored locally and a OCPP backend is used, a comparison takes place with the RFID cards stored at the OCPP backend.
<b>First online</b>	The authorization request is always compared to the RFID cards stored on the OCPP backend. There is no comparison to the RFID cards stored locally at the charging station unless the charging station is "offline."
<b>Only local</b>	The authorization request is always compared to the RFID cards stored locally at the charging station. No comparison is made to the RFID cards stored at the OCPP backend.

### Authorization with/without OCPP backend (no connection)

This defines how an authorization request is handled if the connection to the higher-level OCPP backend fails or an OCPP backend is not used.

Mode	Description
<b>Offline local unknown authorization</b>	All RFID cards are accepted, even if they are not stored locally at the charging station. Only those RFID cards that are stored locally at the charging station and have a status other than "ACCEPTED" are rejected.
<b>Offline local authorization</b>	Only RFID cards stored locally at the charging station with the status of "ACCEPTED" are accepted.
<b>Offline no authorization</b>	All RFID cards are temporarily accepted. As soon as the connection to the OCPP backend exists again, the RFID card is checked and, if an invalid RFID card is being used, the charging process is canceled.
<b>Offline no charging</b>	Charging is not possible in case of a connection failure.
<b>Offline free charging</b>	Authorization is deactivated in case of a connection failure; the RFID card does not have to be held up.

### Local authorization without OCPP backend

For a charging station with RFID functionality that is not using an OCPP backend, the setting from the table "Authorization with/without OCPP backend (no connection)" applies.

Standard: **Offline local authorization**

#### Information

*The setting from the table "Authorization with OCPP backend (with connection)" is not taken into account.*

## 14 Special functions

### 14.1 Integration of an external energy meter

The charging station can read out measured values from an external energy meter. This allows an intelligent calculation of the charging current for the vehicle, and the charging process is optimized. The measured values that are read out are included in the charging current specification.

The energy meter must be connected with the same phase sequence as the charging station so that the house load calculation and the charging optimization can be carried out correctly. If it is necessary to connect the charging station beginning with phase 2 in order to better distribute the phase loads, the energy meter must also be connected beginning with phase 2.

#### Schematic diagram

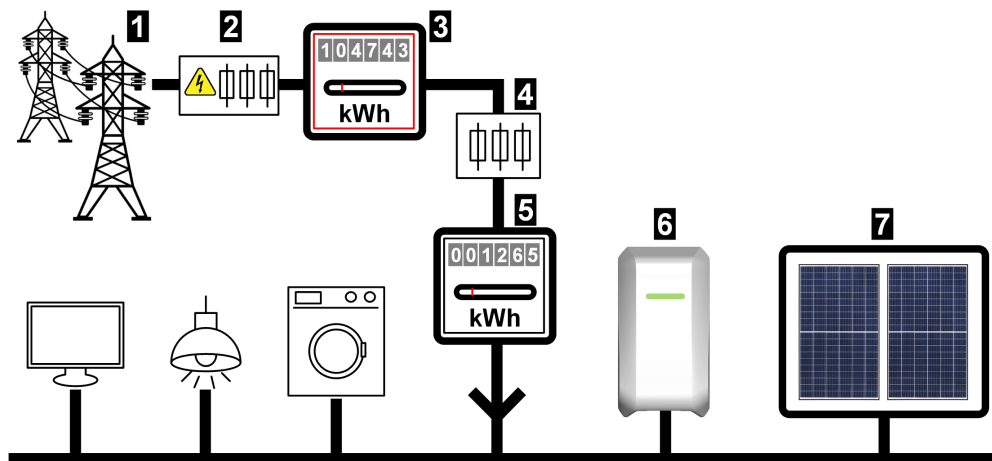

Fig. 14-4: System overview - Integration of an external energy meter

<b>1</b> ... Public power grid	<b>2</b> ... Pre-meter circuit breaker
<b>3</b> ... Electricity meter of the energy supply company	<b>4</b> ... Post-meter circuit breaker
<b>5</b> ... External energy meter	<b>6</b> ... Charging station
<b>7</b> ... Optional PV system	

#### Information

*The illustration provides an example system overview and does not include all the necessary auxiliary devices required for safe operation of the system (e.g. line circuit breaker, residual current device, etc.).*

## 14.2 Connection of an external energy meter (Modbus TCP)

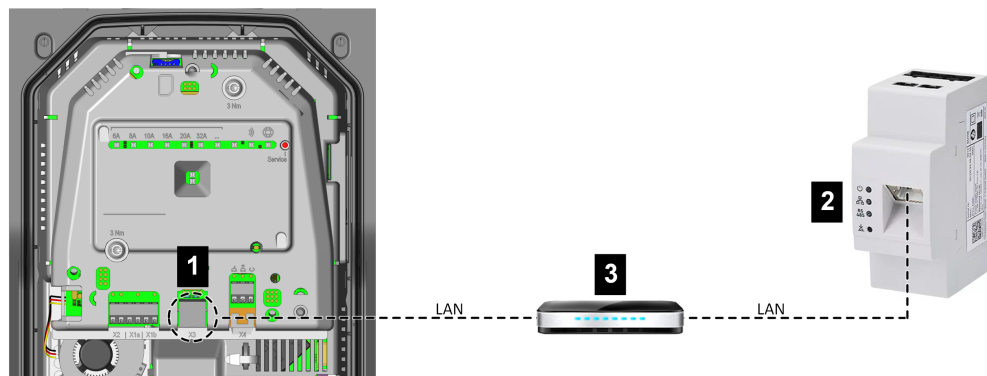

<b>1</b> ... Network connection of the charging station	<b>2</b> ... Energy meter in the control cabinet
<b>3</b> ... Router/switch	

**Information**

- The connection of the charging station to the router or switch can optionally take place via WLAN, depending on the device.
- The energy meter must be in the same network (LAN) as the charging station.

## 14.3 Connection of an external energy meter (RTU)\*

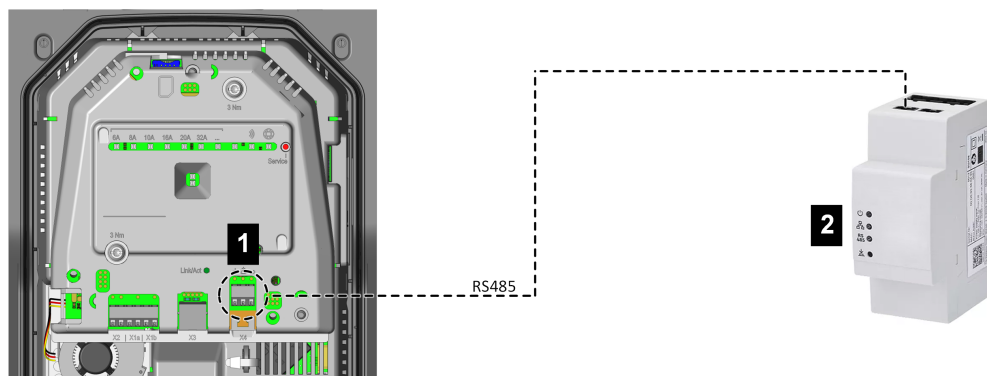

<b>1</b> ... RS485 connection of the charging station	<b>2</b> ... Energy meter in the control cabinet
---	--

\*)... Function will be made available with a later software update.

The RS485 interface (Modbus-compatible) of the charging station is deactivated by default. If an external energy meter (Modbus RTU) is installed in the system, this interface must be configured.

Activation and configuration of this function takes place using KEBA eMobility App.

## 14.4 Supported external energy meters

### Supported TCP energy meters

Manufacturer	Model	Phases / Current	TCP port / Modbus address
KEBA Energy Automation	KeContact E10	3 / 63 A	502 / 1
KEBA Energy Automation	KeContact E10 <sup>1)</sup>	1 / 63 A	502 / 1
ABB	M2M	3+N / -	-
ABB	M4M	3+N / -	-
Carlo Gavazzi	EM 24	3+N / -	-
Fronius	Fronius Smart Meter TS 65A via Symo GEN24	3+N / 65 A	502 / 200
Fronius	Data manager	-	502 / 240
Gossen Metrawatt	EM2289-V027	3+N / 80 A	-
KOSTAL	Smart Energy Meter	3+N / 63 A	-
Siemens	7KM2200	3+N / 65 A	-

These 3-phase energy meters are suitable for the "Dynamic domestic connection monitoring" and "PV-optimized charging" functions.

<sup>1)</sup> 1-phase meters do not support "Dynamic domestic connection monitoring."

### RTU energy meters\*

Manufacturer	Model	Phases / Current	Information
ABB	B23 312-100	3+N / 65 A	*) These meters can only be used after a subsequent software update to support the prepared RS485 interface.
ABB	B21 312-100	1+N / 65 A	
Janitza	B23 312-10J	3+N / 65 A	
Janitza	B21 312-10J	1+N / 65 A	
EASTRON	SDM72D-M-2	3+N / 100 A	
EASTRON	SDM120 Modbus	1+N / 45 A	
EASTRON	SDM230 Modbus	1+N / 100 A	
EASTRON	SDM630 Modbus	3+N / 80 A	
Schneider	A9MEM3155	3+N / 63 A	
Hager	ECR180D	1+N / 80 A	
Hager	ECR380D	3+N / 80 A	

These 3-phase energy meters are suitable for the "Dynamic domestic connection monitoring" and "PV-optimized charging" functions.

**Information**

*Detailed information about the meter installation can be found in the installation instructions of the meter manufacturer.*

## 14.5 Dynamic domestic connection monitoring

Using the "Domestic connection monitoring" function, the charging current of a vehicle can be adjusted dynamically so that the domestic connection is not overloaded. The charging current is regulated based on the remaining consumers on the domestic connection.

This function can extend the charging time of the vehicle. Temporary deactivation of this function (charging boost) is not possible, as this could overload the domestic connection.

Activation and configuration of this function takes place using KEBA eMobility App.

**Requirements**

- 3-phase external energy meter (see "[14.1 Integration of an external energy meter](#)").

**Regulation principle**

The charging station can read out the current total energy supply from the power grid via the external energy meter. The charging station can use this information to regulate the maximum charging current so that the defined maximum amperage and power is not exceeded. This ensures that the service fuses are not overloaded or that a lower charging power does not always have to be selected during installation.

**Necessary settings at the charging station**

Parameter	Setting
Domestic connection monitoring	ON
Max. permitted charging current per phase [A]	Maximum permitted current per phase in amperes at the power connection point.
Max. permitted power [kW]	Maximum permitted power in kW at the power connection point.

Parameter	Setting
Power in case of connection loss [kW]	<p>If the connection to the external meter is interrupted, the charging power at which charging is to continue can be set here. If "0" is entered or if the field remains empty, the charging process is canceled in the event that the connection to the external meter is interrupted (recommended).</p> <p><b>If a value that is too high is entered for this parameter, this can cause the domestic connection to be overloaded in case of a connection failure.</b></p>

## 14.6 PV-optimized charging

Using the "PV-optimized charging" function, the charging process of a vehicle can be optimized based on the energy generated by a PV system.

This function can extend the charging time of the vehicle. This function can be temporarily deactivated (charging boost) using KEBA eMobility App, the touch button (depending on the variant) or a switch contact input.

Activation and configuration of this function takes place using KEBA eMobility App.

### Prerequisite

- 1-/3-phase external energy meter (see "[14.1 Integration of an external energy meter](#)").

### Regulation principle

Using the external energy meter, the charging station can read out any surplus power of a PV system that is fed into the public power grid. The charging station can use this information to regulate the maximum charging current so that the electricity volume is minimized. This also takes into account the remaining consumers on the domestic connection.

### Necessary settings at the charging station

Parameter	Setting
PV-optimized charging	ON
Minimum portion of photovoltaic power [%]	<p>Minimum portion of photovoltaic power (%) of the total charging power, at which the charging process is started.</p> <p>The charging process always begins with the minimum charging power and is only increased if the charging power can be provided entirely by the PV system.</p>

Parameter	Setting
Duration of charging boost from start [minutes]	Period for which full charging power is to be used at the start of each charging session to ensure of the vehicle always has a minimum range.
Ignore PV using X1	Enable deactivation of PV-optimized charging using the switch contact input X1.
PV control interval [seconds]	Minimum time interval that must pass before the charging power is adjusted again.
Control threshold – Import [W]	Threshold value for the amount of power (W) from the power grid that must be exceeded to trigger a new calculation of the charging power (reduction). A higher value leads to less control adjustments, but may lead to a greater amount from the power grid.
Control threshold – Export [W]	Threshold value for the delivery of power (W) into the power grid that must be exceeded to trigger a new calculation of the charging power (increase). A higher value leads to less control adjustments, but may lead to a greater delivery into the power grid.
Phase deactivation 3p.→1p.	Activates automatic phase deactivation for 3-phase charging stations.

### Automatic phase deactivation (3p.→1p.)

Electric vehicles generally require a minimum charging current of 6 A per phase. This results in the following minimum charging capacities:

- 1-phase connection = 1.38 kW
- 3-phase connection = 4.14 kW

To reduce the minimum charging capacity for 3-phase charging stations, an automatic change to 1-phase charging can occur with the corresponding setting. It must be ensured that control technology delays can be effective during phase deactivation.

Phases	Switching condition
3p.→1p.	If the minimum charging current for all 3 phases cannot be provided any longer → available charging capacity < 4.14 kW.
1p.→3p.	If the minimum charging current on all 3 phases can be provided again → available charging capacity > 4.14 kW.

## 14.7 Remote control by the power grid operator

Grid operators in Europe and other countries may stipulate that the charging capacity can be limited remotely. This is used to limit the electricity volume of devices with high consumption during peak usage times in the power grid.

Activation and configuration of this function takes place using KEBA eMobility App.

### Regulation principle

A corresponding switching signal for power limiting by the grid operator must be connected to a switch contact input [X1]. The charging power of the charging station is limited with an active switching signal.

If the grid operator removes the switching signal for limiting the charging power, the charging power is slowly raised back up over a defined time period.

### Connection diagram

For details on the connection of a switch contact input, see "[9.6 Switch contact inputs \[X1a\] / \[X1b\]](#)."

### Necessary settings at the charging station

Parameter	Setting
X1x switch contact input activated	ON
X1x switch contact input function	Max. charging / reduced charging
X1x switch contact input current limit	Set value in amperes for reduced charging

## 14.8 Smart Home Interface

The charging station offers the option to forward information and receive commands over the **REST-API** interface. For instance, this can be used for integration into a smart home.

## 14.9 Charging profiles

Any charging profile can be created and assigned for a charging station registered in the KEBA eMobility Portal. This enables the programming of time-dependent charging powers (e.g. time windows with certain maximum charging powers).

To use this feature, follow these steps:

- 1) Registration of a user in the KEBA eMobility Portal.
- 2) Registration of the charging station in the KEBA eMobility Portal.
- 3) Creation of a charging profile in the “Charging optimization” menu item.
- 4) Assignment of the charging profile to the desired charging station.

### Information

- The factory-configured charging profiles of a charging station are not displayed in the KEBA eMobility Portal, but are effective. If a charging profile is set by the user, the factory-configured charging profile is overwritten and becomes ineffective.
- The charging profiles of a charging station cannot be changed with the KEBA eMobility App.

## 14.10 Tamper detection

The charging station has integrated tamper detection. This detects when the protective cover is removed during operation. In this case, a message is sent to the KEBA eMobility App and, if necessary, an OCPP message to the operator.

Depending on national regulations, the use of this function may be mandatory.

## 15 OCPP backend

The charging station offers the option of being connected to a central management system via the Open Charge Point Protocol (OCPP). OCPP, as an open application protocol, makes it possible to connect any central management system to the charging station regardless of the manufacturer or supplier. The following OCPP version is supported:

- OCPP 1.6 via JSON

### Connection to an OCPP backend

When connecting to an OCPP backend, note the following:

- It is recommended that the charging station in the network be assigned a static IP address based on the MAC address of the device.
- Since the OCPP backend is usually not in the same network, the charging station must be assigned a "public IP address" which is routed to the internal IP address (NAT).
- The firewall must be configured so that communication between the charging station and OCPP backend is possible.
- For a connection via VPN, the IP address of the VPN must be specified in the configuration for the downlink.
- In the case of a mobile communications connection, it may be necessary for the required ports to be activated by the cellular service provider.

### Ports for communication via OCPP

For communication with an OCPP backend, the following ports must be enabled in the network:

Port	Protocol	Definition	Description
Custom (1025 - 65535)	TCP	Can be reached externally (incoming)	OCPP Charge Point Service: This service is related to the OCPP backend. <ul style="list-style-type: none"> <li>• The port can be freely selected or it is specified by the OCPP backend. However, the port may only be located in the range from 1025 to 65535.</li> <li>• The selected port must be configured on the charging station.</li> </ul>
Custom	TCP	Access to external (outgoing)	Port at which the OCPP backend can be reached.
123	UDP	Incoming and outgoing	Port for optional connection with an NTP server (time server).

## Supported OCPP messages

Message
Authorize
BootNotification
ChangeAvailability
ChangeConfiguration
ClearCache
DataTransfer
GetConfiguration
Heartbeat
MeterValues
RemoteStartTransaction
RemoteStopTransaction
Reset
StartTransaction
StatusNotification
StopTransaction
UnlockConnector
GetDiagnostics
DiagnosticsStatusNotification
FirmwareStatusNotification
UpdateFirmware
GetLocalListVersion
SendLocalList
CancelReservation
ReserveNow
ClearChargingProfile
GetCompositeSchedule
SetChargingProfile
TriggerMessage

## 16 Short description of the eMobility App



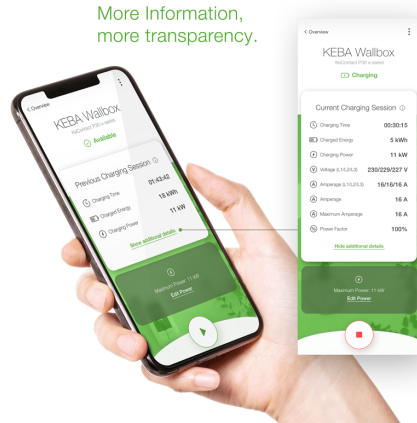



The KEBA eMobility App is an extended user interface for the charging station and can be used for the following applications:



- View the current status.
- Start and stop charging processes.
- View information on past charging sessions.
- Set the charging power.
- Use comprehensive configuration options.
- Manage RFID cards.
- Perform a software update.

Connection options for the KEBA eMobility App:

- Local connection via Bluetooth® wireless technology.
- Connection via LAN/WLAN in own network.
- Connection of a smartphone to the charging station worldwide via the Internet (remote access). For this, the charging station must be connected to the Internet.
- KEBA eMobility Portal

Downloading the app		
 Download page of the manufacturer	<a href="http://www.keba.com/emobility-app">http://www.keba.com/emobility-app</a>	
	<a href="https://play.google.com/store/apps/details?id=com.keba.emobility.app">https://play.google.com/store/apps/details?id=com.keba.emobility.app</a>	
	<a href="https://apps.apple.com/us/app/keba-emobility-app/id1614805616">https://apps.apple.com/us/app/keba-emobility-app/id1614805616</a>	
Google™, Google Play™ and their logos are trademarks of Google Inc in the US and other countries. Apple®, App Store® and their logos are registered trademarks of Apple Inc in the US and other countries.		

## Operating mode and configuration options of the app

The initial network settings of the charging station can only be configured on site via a Bluetooth® connection. For the charging station's extended scope of configuration, a connection between the app and charging station via LAN, WLAN or WLAN hotspot is required.

App mode	Connection	Remarks
Setup guide	Bluetooth®	<p>Selection of the charging station and connection.</p> <p><b>Access protection:</b></p> <ul style="list-style-type: none"> <li>Bluetooth® PIN + <b>User PWD</b> password (see sticker on the back side of the included short manual)</li> <li>Alternative: Scan QR code (see sticker on the back side of the included short manual)</li> </ul>
Network configuration wizard	Bluetooth®	<p>Configuration of the network connection (LAN, WLAN or WLAN hotspot).</p>
Installer mode	Bluetooth®	<p>Basic electrical settings of the charging station.</p> <p><b>Access protection:</b></p> <ul style="list-style-type: none"> <li>Service key in the charging station and <b>Installer PWD</b> password (see sticker on the back side of the included short manual)</li> </ul> <p><b>Possible settings are:</b></p> <ul style="list-style-type: none"> <li>Maximum charging current</li> <li>Power supply</li> <li>Phase rotation</li> <li>Avoid asymmetrical loads</li> <li>Switch contact inputs (X1a, X1b) and switch contact output (X2), with the option to lock them.</li> </ul>
User mode	LAN, WLAN, WLAN hotspot	<p>Full app functionality and full scope of settings.</p> <p><b>Access protection:</b></p> <ul style="list-style-type: none"> <li><b>User PWD</b> password (see sticker on the back side of the included short manual)</li> </ul> <p><b>Possible settings are:</b></p> <ul style="list-style-type: none"> <li>Start and stop charging processes</li> <li>Comprehensive configuration options (interfaces)</li> <li>RFID card management</li> <li>And much more</li> </ul>

## 16.1 Establishing an app connection via Bluetooth®

For the initial use of the KEBA eMobility App and for configuring or operating the charging station, proceed as follows:

- 1) Install the KEBA eMobility App on your mobile device.
- 2) Switch on the mobile device's Bluetooth® function.
- 3) The power supply for the charging station must be switched on. The integrated Bluetooth® function is activated by default upon delivery. If the Bluetooth® function is deactivated, it can be activated using a LAN/WLAN connection or by activating installation mode (directly at the device).
- 4) Be within a distance of maximum 10 m from the charging station to enable wireless communication.
- 5) Open the KEBA eMobility App.
- 6) Select the corresponding charging station or add a new charging station using the **[+]** button.
- 7) For a newly added charging station, enter the **PIN** of the charging station (see sticker on the back side of the included short manual).
- 8) Select the **"User"** or **"Installer"** role and enter the corresponding User PWD/Installer PWD password (see sticker on the back side of the included short manual).

The connection to the charging station is established.

## 16.2 Establishing an app connection via LAN/WLAN

To configure a LAN or WLAN connection for the first time, proceed as follows:

- 1) Move within 10 m of the charging station to enable radio communication.
- 2) Open the KEBA eMobility App and establish a Bluetooth® connection to the charging station.
- 3) In the KEBA eMobility App run the **„Network-Configuration-Wizard“** and make the desired LAN/WLAN settings.

The charging station can then be reached via a LAN/WLAN connection.

If the connection has already been established via a LAN/WLAN network with the mobile device used, the charging station remembers this connection data. To use the app, proceed as follows:

- 1) Start the KEBA eMobility App and establish the connection to the charging station. Re-entering the PIN is not necessary.

The connection to the charging station is established.

## 17 Short description of the eMobility portal

The KEBA eMobility Portal (<https://emobility-portal.keba.com/>) is next to the KEBA eMobility App the digital interface between you and your charging station or entire charging networks. Once logged in, you can use a variety of functions on your PC or tablet:

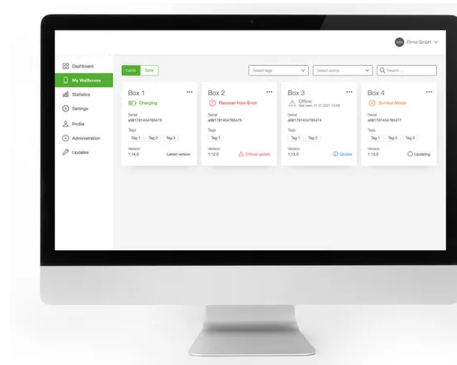

- Management of charging stations at different locations
- View details of connected charging stations (charging sessions)
- One-click software update
- Planning charging time windows with defined maximum power (charging profiles)
- RFID card management
- Filter charging sessions by RFID cards, charging stations, etc.
- Creating reports and statistics
- Automatic charging reports via email
- Advanced configuration options
- Invite additional users with different roles and rights

### Using the KEBA eMobility Portal for the first time

- 1) Creating a new portal account in the KEBA eMobility Portal under: <https://emobility-portal.keba.com/>  
The person who creates the portal account receives the role of “owner” of the portal account.
- 2) Optional:  
In the created portal account, additional users with different roles (rights) can be invited. Charging stations can then be assigned to these users.

### Register the charging station in the KEBA eMobility Portal

Requirements:

- The charging station must be operational and connected to the Internet via LAN or WLAN.
- The charging station and the mobile device with the installed KEBA eMobility App must be in the same network.
- Portal account and optional users were created in the KEBA eMobility Portal.

To register the charging station in the KEBA eMobility Portal, proceed as follows:

- 1) Log in to the charging station via LAN or WLAN using the KEBA eMobility App.
- 2) Register the charging station using the app (“Add Wallbox to portal account” menu item) in the KEBA eMobility Portal. To do this, follow the instructions on the screen.

**Information**

*The KEBA eMobility Portal and another OCPP backend cannot be used at the same time.*

## 18 Maintenance

The hardware of the charging station is fundamentally maintenance-free, but must be regularly checked by the customer or system operator for defects on the charging plug (including charging cable) and for housing damage (visual inspection).

### 18.1 Software update

The software of the charging station is subject to mandatory updates in accordance with the EU Directives "Sale of goods 2019/771" and "Digital content 2019/770" and their national versions.

The software of the charging station must therefore always be kept up to date, as updates may contain safety updates, function extensions and bug fixes.

**A software update can be obtained through the following sources:**

- KEBA eMobility App
- KEBA eMobility Portal
- Download address: [www.keba.com/emobility-downloads](http://www.keba.com/emobility-downloads)
- OCPP backend

The information and instructions for the current software package from the associated release notes must be observed.

#### Information

- A software update is only performed if a vehicle is not connected to the charging station.
- Software updates may take some time. The update process is indicated by a slow orange flashing of the LED bar.
- The power supply must not be interrupted during the software update. Otherwise, the software update will not end correctly and continued normal operation of the charging station is no longer ensured.
- After the software update, the charging station restarts automatically.

#### Software update with KEBA eMobility App

To update the software of the charging station, proceed as follows:

- 1) Open KEBA eMobility App and connect with the charging station.
- 2) A more recent software version is shown in the app. The update process can be started directly from there.

**Alternative:**

- 1) Download a software update package from the manufacturer's website and copy it to the mobile device.
- 2) Open KEBA eMobility App and connect with the charging station.
- 3) Manually select the software update package in the app and transfer it to the charging station.

Depending on the device variant, the charging station may be integrated into the network differently:

- LAN connection
- WLAN connection

### Software update via KEBA eMobility Portal

If the charging station is registered in KEBA eMobility Portal and connected with it, a software update can be initiated conveniently through the portal.

In the portal, the RAUC update method can also be selected, for example. Using this method, files are only transferred for which the charging station does not yet have the latest version.

### Software update via OCPP backend

A software update for the entire charging network can be executed via the OCPP backend.

An HTTP link is required for the software update. The HTTP link is located with the information available for download along with the software update on our website.

Details on using the HTTP link can be found in the instructions for the OCPP backend.

## 18.2 Troubleshooting

Further information (e.g. instructions) and contact details are available on our website:

[www.keba.com/emobility-downloads](http://www.keba.com/emobility-downloads)

## 19 Accessories

### 19.1 Floor-mounted columns

KeContact P40 is suitable for installation on the following floor-mounted columns.

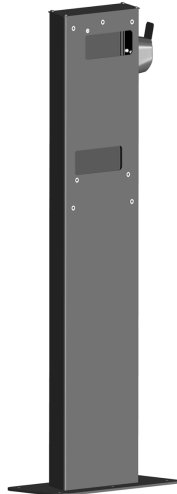

#### **Floor-mounted column (aluminum) V1: #131 771**

The floor-mounted column is suitable for the installation of one charging station.

#### **Floor-mounted column (aluminum) V2: #131 813**

The floor-mounted column is suitable for the installation of two charging stations on it.

## 20 Disposal

---

### Caution

Please observe the regulations regarding disposal of electric appliances and electronic devices!

---



- The symbol with the crossed-out waste container means that electrical and electronic devices including their accessories must not be disposed of in the household garbage.
- The materials are recyclable in accordance with their labeling. You can make an important contribution to protecting our environment by reusing, renewing and recycling materials and old appliances.

### Sustainability

Please consider the environment. The device contains valuable raw materials which should be recycled.

## 21 Technical data

### 21.1 General

Charge mode:	Mode 3 in accordance with EN 61851-1 AC charging
Overvoltage category:	III in accordance with EN 60664
Protection class:	I
Protection type:	IP54
Protection against mechanical impact:	IK10
Rated short-time withstand current:	< 3 kA (effective value in accordance with EN 61439-1)
Ventilation:	If ventilation is requested by the vehicle, charging will not be started

### 21.2 Power supply

Nominal supply voltage (Europe):	230/3x230(400) V 16 A / 32 A
Nominal current:	Current limit adjustable via service button: 6 A, 8 A, 10 A, 16 A, 20 A, 32 A Current limit freely adjustable via app between 6 A and 16/32 A in 1 A steps
Line frequency:	50 Hz
Mains forms:	TT (230/400 V) / TN (230/400 V) / IT (230 V)
Required upstream short-circuit protective device:	≤35 A gG (gL) according to EN 61008/IEC 61439 ≤25 A gG (gL) for the "Early Access Edition" device variants (KC-P40-16EUS-C6S1AEP0-LS1R1111BL0-WH00 and KC-P40-16EUS-C6S1AEP0-LS1R1111BL0-BK00)
Internal consumption:	<ul style="list-style-type: none"> <li>• Idle: 2,5 W (Eco / Sleep mode)</li> <li>• Vehicle plugged in: 4 W (paused)</li> <li>• Vehicle plugged in: 6 W (charging)</li> </ul>

#### Supply terminals

Type:	Push-in spring terminals
Cable feed:	Bottom side (surface-mounted), rear side (flush-mounted)
Connection cross-section of the supply:	Depending on the cable and the type of installation
• 16 A nominal current:	2,5-10 mm <sup>2</sup> / AWG 13-7
• 32 A nominal current:	6,0-10 mm <sup>2</sup> / AWG 9-7
Stripping length:	18 mm
Maximum terminal temperature:	90 °C

## 21.3 Charging cable

Cable variants:

- Type 2: up to 32 A / 400 V AC (in accordance with EN 62196-1, EN 62196-2, EN 17186)
- Type 2 including shutter: up to 32 A / 400 V AC (in accordance with EN 62196-1, EN 62196-2, EN 17186)

## 21.4 Ambient conditions

Application:	Inside and outside area
Installation (stationary):	On the wall or on a floor-mounted column
Operating temperature:	Data without direct sunlight
• Variants with certified meter:	-25 °C ... +50 °C
• Variants without certified meter:	-30 °C ... +50 °C
Maximum temperature for continuous current without derating:	
• 3x16 A nominal current:	+45 °C (+50 °C with integrated case fan)
• 1x32 A nominal current:	+38 °C
• 3x32 A nominal current:	+40 °C with integrated case fan
Storage temperature:	-30 °C to +80 °C
Altitude:	max. 2.000 m above sea level
Temperature behavior:	Automatic charging current reduction if overheating occurs

## 21.5 Interfaces

### WLAN

Type:	IEEE 802.11 b,g,n
Band:	2,4 GHz
Supported modes:	AP Ad-hoc-Mode, Client mode

### Ethernet interface

Ethernet interface:	RJ45
Data transfer rate:	10/100 Mbit/s
Potential isolation:	Isolation voltage 1500 V AC (1 min.)

### Bluetooth®

Bluetooth® standard:	BLE 5.0 or higher
Intended use:	Connection with KEBA eMobility App
Band:	2,4 GHz

**Switch contact inputs [X1a / X1b]**

Type:	Connections for external, potential-free switch contacts
Quantity:	2
Intended use:	Authorization, charging current reduction, charging pause, simplified charging management with 2 charging stations*
Voltage:	12 V DC PELV (2,5 mA)
Permitted switching element:	(External) potential-free switch contact
Terminal type:	Push-in spring terminals
Conductor cross-section of the terminals:	<ul style="list-style-type: none"> <li>• Rigid conductor: 0,13–1,5 mm<sup>2</sup> / AWG 28–14</li> <li>• Flexible conductor: 0,13–1,5 mm<sup>2</sup> / AWG 28–14</li> <li>• Flexible conductor with wire end ferrules: max. 0,75 mm<sup>2</sup> / AWG 19</li> </ul>
Stripping length:	10 mm

**Switch contact output [X2]**

Type:	Internal, potential-free switch contact
Quantity:	1
Intended use:	Main-relay monitoring, charging status
Potential isolation:	Isolation voltage 1500 V AC (1 min.)
Permitted switching voltage:	External SELV/PELV safety extra-low voltage; < 30 V AC (50/60 Hz) / ≤ 60 V DC
Required current limitation:	< 0,5 A
Terminal type:	Push-in spring terminals
Conductor cross-section of the terminals:	<ul style="list-style-type: none"> <li>• Rigid conductor: 0,13–1,5 mm<sup>2</sup> / AWG 28–14</li> <li>• Flexible conductor: 0,13–1,5 mm<sup>2</sup> / AWG 28–14</li> <li>• Flexible conductor with wire end ferrules: max. 0,75 mm<sup>2</sup> / AWG 19</li> </ul>
Stripping length:	10 mm

**RS485 interface (Modbus RTU compatible)\***

Intended use:	Communication with external energy meter (Modbus RTU compatible)
Potential isolation:	Isolation voltage 1500 V AC (1 min.)
Terminal type:	Push-in spring terminals
Conductor cross-section of the terminals:	<ul style="list-style-type: none"> <li>• Rigid conductor: 0,13–1,5 mm<sup>2</sup> / AWG 28–14</li> <li>• Flexible conductor: 0,13–1,5 mm<sup>2</sup> / AWG 28–14</li> <li>• Flexible conductor with wire end ferrule: max. 0,75 mm<sup>2</sup> / AWG 19</li> </ul>
Stripping length:	10 mm

**PLC (Power Line Communication)\* // only KeContact P40 Pro**

Communication with the vehicle:	ISO 15118 ready*
---------------------------------	------------------

\*)... Function will be made available with a later software update.

## 21.6 Equipment depends on version

### RFID function

Supported standards:	ISO 14443 or ISO 15693
Frequency:	13.56 MHz

### Touch button [TB]

Type:	Capacitive button (e.g. for switching to fast charging mode)
-------	--

### Mobile communication [4G/LTE]

Type:	4G with fallback to 2G
Supported LTE (4G) bands:	B1, B3, B7, B8, B20, B28
Supported GSM (2G) bands:	Band 900 / 1800
Maximum data rate: (depends on external influences)	LTE Cat.1bis download: 10,2 MBit/s upload: 5,2 MBit/s
SIM card:	SIM card with 4G authentication Size: Micro-SIM (3FF) Type: Industrial/M2M recommended

### Energy meter

Meter type:	Electricity meter for active power
Variants of the energy meter:	<ul style="list-style-type: none"> <li>• Functional (not calibratable)</li> <li>• MID</li> <li>• MessEV</li> </ul>

## 21.7 Internal protective functions

### Residual current circuit breaker RCCB Typ A

Behavior in the event of mains voltage failure:	According EN 61008-1:2018 (4.1.2.1 b) E2 - Switches off automatically without delay when the mains voltage fails and does not switch on again automatically when it returns.
Self-test:	A self-test is carried out immediately before each new charging session.
Number of poles:	2/4 (depending on the respective device variant)
Resistance to unintentional triggering due to surge voltages:	General type
Behavior when direct current parts occur:	Type A

Time delay in the event of a fault current:	Type for general use
Mounting method:	Installation type
Method of connection:	Connections are independent of the mechanical mounting
Type of terminals:	Screwless terminals for external copper wires
Rated voltage:	$U_n = 230/400 \text{ V}$
Rated frequency:	50 Hz
Rated current:	$I_n = 32 \text{ A}$
Rated DC residual operating current:	$I_{\Delta n} = 0.03 \text{ A}$
Rated making and breaking capacity:	$I_m = 500 \text{ A}$
Rated conditional short-circuit current:	$I_{nc} = 3000 \text{ A}$
Degree of protection:	IP 10

### DC fault current monitoring RDC-DD

Type of construction:	According IEC 62955:2018 (4.1.2) RDC-PD with integrated AC, pulsating DC and 6 mA DC detection, evaluation and mechanical switching in one unit
Number of poles:	2/4 (depending on the respective device variant)
Method of connection:	Independent of the mechanical mounting
Type of terminals:	Screwless terminals for external copper wires
Rated voltage:	$U_n = 230/400 \text{ V}$
Rated frequency:	50 Hz
Rated current:	$I_n = 32 \text{ A}$
Rated DC residual operating current:	$I_{\Delta dc} = 0.006 \text{ A}$
Rated making and breaking capacity:	$I_m = 500 \text{ A}$
Rated conditional short-circuit current:	$I_{nc} = 3000 \text{ A}$
Degree of protection:	IP 10

## 21.8 Dimensions and weight

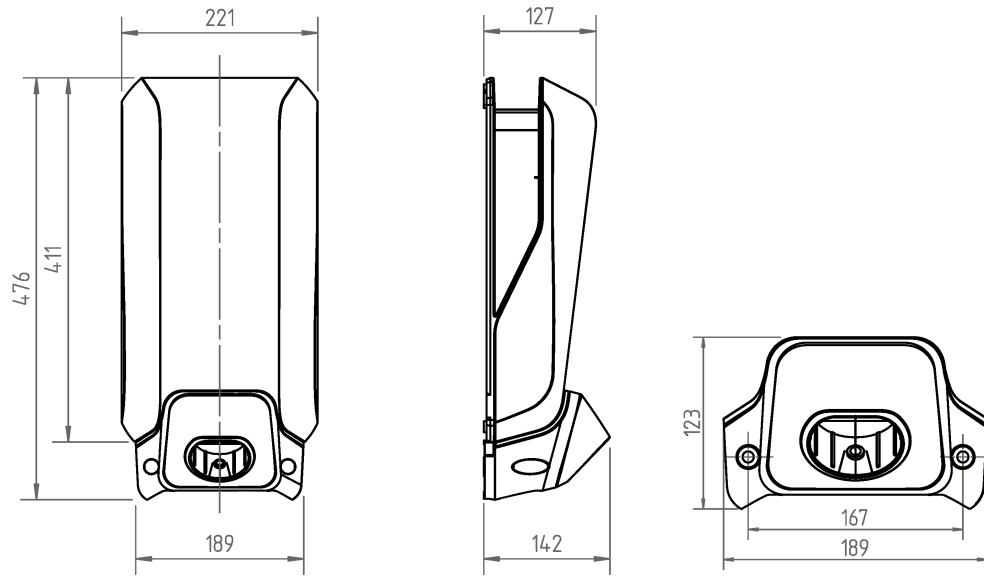

Fig. 21-5: Dimensions in millimeter

Height / width / depth:	476 mm / 221 mm / 142 mm
Weight of the charging station (including 6m charging cable):	~ 6,2 kg (depending on variant)
Dimensions of the packaging:	590 mm x 280 mm x 258 mm

## 22 EU Directives and Standards

2014/53/EU	Radio Equipment Directive (RED)
2011/65/EU	Directive on the restriction of the use of certain hazardous substances (RoHS)
2012/19/EU	Directive for waste electrical and electronic equipment (WEEE)
2014/32/EU	European Measuring Device Directive (MID)

## 23 Country-specific characteristics

### 23.1 Country-specific settings for Great Britain / United Kingdom

#### Defined charging profiles (time windows)

According to national guidelines and regulations, the following charging profiles are set by default on the charging station. Weekday charging times from **8:00 a.m. to 11:00 a.m.** and **4:00 p.m. to 10:00 p.m.** are factory disabled to prevent electric vehicles from charging at peak times.

To meet national requirements, the charging station must be online during commissioning so that the correct time (UTC) is set on the charging station.

You can also automatically synchronize the correct time by connecting to the KEBA eMobility App.

#### Tamper detection

In accordance with national guidelines and regulations, tamper detection is already activated ex works for these device variants.

### 23.2 Country-specific characteristics for Germany

#### §14a EnWG (Energy Industry Act)

In order not to overload the existing power grid at peak times of demand, the electricity grid operator is entitled to limit the grid-relevant power consumption of controllable consumption devices (e.g. a charging station) to a value of 4.2 kW. According to Section 14a of the Energy Industry Act, operators of a charging station are obliged to ensure this controllability for new installations from January 1, 2024. The charging station offers the following interfaces for control:

- Switch contact inputs X1a/X1b
- Modbus TCP
- OCPP

With the appropriate configuration, the available charging current can be reduced accordingly. For details on the setting, see also chapter „[14.7 Remote control by the power grid operator](#)“.

## Index

**A**

Accessories	
Floor-mounted columns .....	83
Activating installation mode .....	53
App	
Connection via Bluetooth® .....	55, 78
Establishing an app connection via LAN/ WLAN .....	78
Audio signals .....	18

**B**

Bluetooth®	
Activation .....	58
Deactivation .....	58
Showing the status .....	58
Buzzer .....	18

**C**

Cable glands .....	30
Cable routing .....	33
Charging current specification .....	24
Charging profiles .....	73
Settings for UK .....	92
Configuration .....	52
Basic electrical configuration and param- eterization using the app .....	55
Basic electrical configuration directly at the device .....	54
Operation and extended configuration using the app .....	57
Parameter .....	55, 57
Connecting the power supply line .....	36
Connecting the voltage supply .....	36
Connection diagram X1x .....	40
Connection diagram X2 .....	42
Connection overview	
Application module .....	39

**D**

Deactivating installation mode .....	53
Disconnection device .....	23
Domestic connection monitoring .....	69
Drilling template .....	32

**E**

Ethernet .....	45
External energy meter	
Integration .....	66
Modbus TCP connection .....	67
RS485 Connection .....	67

**F**

Fitting the housing cover .....	62
Front view of the charging station .....	12

**H**

Hole positions .....	31
----------------------	----

**I**

Information on this document .....	8
Installation instructions .....	25
Installation notes .....	25
Intended use .....	7

**L**

LAN connection .....	45
LED bar .....	18
Authorization functions .....	19
Common operating states .....	19
Configuration .....	20, 59
Display information .....	18
Error states .....	20
Line circuit breaker .....	24
Location selection .....	26

**M**

Maintenance .....	81
Mobile network .....	50
Modbus RTU-compatible .....	47
Mount covers .....	61
Mounting the charging station .....	29, 32
Mounting the plug holder .....	63
Mounting the terminal cover .....	61

**N**

Network connection .....	45
Status LED .....	46

**O**

OCPP backend .....	74
Ports for communication .....	74
Supported messages .....	75
Operation with the app .....	76
Overcurrent protection device .....	23

**P**

Phase deactivation 3p.→1p. ....	71
Plug holder .....	13
Power supply line .....	23
Protective cover	
Installation .....	62
Lead seal .....	62
Purpose of the document .....	7
PV-optimized charging .....	70

**R**

RCD .....	23
Rear view .....	14
Remote control by grid operators .....	72
Residual current device .....	23
REST-API .....	72
RFID .....	21
RFID authorization .....	64
Authorization with OCPP backend online .....	64
Authorization with/without OCPP backend offline .....	65
Local authorization without OCPP backend .....	65
RS485 port .....	47
Connection diagram .....	48

**S**

Safety checks .....	60
Safety notes .....	9, 10, 25
Scope of delivery .....	11
Servicing .....	81
SIM card	
Insertion .....	51
Removing .....	51
Smart charging symbol .....	22
Smart Home Interface .....	72
Software update .....	81
Space requirement .....	28
Supported RTU energy meters .....	68
Supported TCP energy meters .....	68
Switch contact inputs .....	40
Switch contact output .....	42
Disconnect solution connection example .....	44
Switching on the power supply .....	49

**T**

Tamper detection .....	73
Settings for UK.....	92
Tool .....	27, 35
Touch button .....	21
Troubleshooting.....	82
Type plates	
Charging station.....	15
Position .....	15

**V**

View from below.....	14
Voltage zones .....	35

**W**

WLAN connection .....	50
-----------------------	----

**X**

X1a.....	40
X1b.....	40
X2.....	42
X3.....	45
X4.....	47





**KEBA Energy Automation GmbH**  
Reindlstraße 51  
4040 Linz / Austria  
[www.keba.com](http://www.keba.com)

**KEBA<sup>®</sup>**  
Automation by innovation.